



**User Manual**

**Mars-100~125KT-F**

**Energy Storage Converter v\_02.04**

## **Copyright statement:**

**Copyright © Shenzhen YUNT Digital Power Co., Ltd. 2025. All rights reserved.**

Without the authorization of Shenzhen YUNT Digital Power Co., Ltd., no part of this manual may be reproduced, transmitted, or uploaded to public networks or third-party platforms in any form.

### **Trademark authorization**

YUNT and other YUNT trademarks used in this manual are owned by Shenzhen YUNT Digital Power Co., Ltd. All other trademarks or registered trademarks mentioned in this manual are owned by their respective owners.

### **Software authorization**

- Do not use any part or all of the data from the firmware or software developed by the company for commercial purposes.
- Do not decompile, decrypt, or perform any other actions that compromise the original program design of the software developed by the company.

### **Notice**

Due to product version upgrades or other reasons, the contents of this document may be updated periodically. Unless otherwise agreed, this document is for guidance only. All statements, information, and suggestions in this document do not constitute any express or implied warranties.

# Contents

1 Product Information .....	9
1.1 Model Description .....	9
1.2 Introduction to the Energy Storage System .....	9
1.3 Principle of the Energy Storage Converter .....	12
1.4 Component Description .....	13
1.5 Product Dimensions .....	14
1.6 LED Indicators on the Panel .....	14
1.7 Technical Specifications .....	15
1.8 Derating curves (voltage, temperature, altitude) .....	17
1.9 Three-phase Unbalanced Output .....	18
2 Unpacking and Handling .....	19
2.1 Transportation and Storage .....	19
2.2 Unpacking .....	19
2.2.1 Precautions for Unpacking .....	19
2.2.2 Unpacking .....	19
2.2.3 Unpacking Inspection .....	20
2.3 Handling .....	20
3 Installation .....	21
3.1 Installation Environment Requirements .....	21
3.2 Installation Tool Requirements .....	22
3.3 Use of Modules in the System Cabinet .....	23
3.3.1 Installation Methods and Precautions .....	23
3.3.2 Cabinet Intake and Exhaust Area Design .....	24
3.3.3 Cabinet Exhaust Fan Selection .....	25
3.4 Installation Steps .....	26
3.5 Cable Preparation .....	28
3.6 Notes for wiring .....	28
3.7 .....	29
3.8 Power Terminal Wiring .....	30
3.9 Signal Terminal Wiring .....	31
4 First Power-On and Operation .....	35
4.1 Power-On Guide .....	35
4.2 Power-Off Guide .....	35
4.2.1 Normal Shutdown .....	35
4.2.2 Emergency Shutdown .....	35
5 Maintenance and Troubleshooting .....	37
5.1 Daily Inspection .....	37
5.2 Regular Inspection .....	38
5.3 Fault List .....	38
6 Appendix .....	41
6.1 Power Terminal Crimping .....	41

# About This Manual

This manual describes the power conversion system (PCS) in terms of its product information, installation wiring, troubleshooting, and maintenance. Please carefully read this manual before installing or using this product, to understand the product safety information and become familiar with the product's functions and features.

## Scope of Application

This manual mainly targets the following equipment:

- Mars-125KT-F energy storage converter
- Mars-110KT-F energy storage converter
- Mars-100KT-F energy storage converter

## Intended Readers

- Energy storage cabinet development engineers
- Hardware installation engineers
- Commissioning engineers
- Maintenance engineers
- Software engineers
- Other technically skilled operators

## Manual Usage

Please read the manual carefully before using the product, and keep it in an accessible place.

The manual content will be continuously updated and corrected, but there may be discrepancies or errors compared to the actual product. Refer to the actual product purchased, and the latest version of the manual can be downloaded and obtained through the YUNT sales channels.

## Revision History

Version	Revision Content	Date
01.00	First release	2024-01
01.01	Added Mars-110KT-F specifications.	2024-02
01.02	Updated structural drawings.	2024-04
01.03	Updated the system air volume.	2024-04
02.00	Refined the rhetoric and some schematic diagrams.	2024-08
02.01	Modified the module usage and installation in the system cabinet.	2024-10
02.02	Corrected the DC+ terminal model.	2024-12
02.03	Modified the recommended temperature difference between intake and exhaust vents and application environment.	2025-06
02.04	Modified safety precautions and PCS application in the system cabinet.	2025-08

# Safety Precautions

## Safety Statement

Before transporting, storing, installing, operating, using, or maintaining the equipment, please read this manual carefully, strictly follow its contents, and comply with all safety instructions indicated on the equipment and in the manual.

The "Danger," "Warning," and "Caution" items in the manual do not represent all safety matters to be observed. You must also comply with relevant international, national, or regional standards, as well as industry practices. The company shall not bear any responsibility for damages caused by violation of safety operation requirements or failure to meet the safety standards in the design, production, and use of the equipment.

This equipment should be used in an environment that meets the design specifications. Any equipment failure, functional abnormalities, or damage to components caused by improper use is not covered under the equipment's quality warranty. The company shall not be responsible for personal injury, property damage, or other consequences resulting from improper use.

All operations during transportation, storage, installation, operation, use, and maintenance shall comply with applicable laws, regulations, standards, and specifications.

It is prohibited to reverse engineer, decompile, disassemble, modify, implant, or otherwise derive operations from the equipment software in any way. The internal logic of the device and the software source code should not be studied or disclosed, nor should any device software performance testing results be revealed.

The company shall not be responsible for the following situations or the results caused by them:

- Damage to equipment caused by natural disasters, such as earthquakes, floods, volcanic eruptions, mudslides, lightning strikes, fires, wars, armed conflicts, typhoons, hurricanes, tornadoes, extreme weather, etc.;
- Operating the equipment outside of the conditions specified in this manual;
- Installation and operational environments not meeting relevant international, national, or regional standards;
- Installation and use performed by unqualified personnel;
- Failure to follow the operational instructions and safety warnings in the product and documentation;
- Unauthorized disassembly, modification of the product, or software code changes;
- Damage caused by transportation handled by you or a third party;
- Damage caused by failure to meet the storage conditions required in the product manual;
- Material and tools provided by you not meeting local laws, regulations, and related standards;
- Damage caused by your or a third party's negligence, intent, gross negligence, improper operation, or reasons not attributable to the company;
- Damage caused by you or a third party failing to perform maintenance as required by the manual, leading to prolonged abnormal operation of the equipment.

## Safety Level Definition

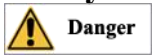

indicates that failure to follow the instructions may result in death or serious bodily injury.



Indicates that serious bodily injury or damage to critical equipment may result if instructions are not followed.



indicates that failure to follow the instructions may result in minor bodily injury or equipment damage.

## Safety Warning Sign Settings

During installation, operation, routine maintenance, and repair of the energy storage converter, please ensure relevant safety measures to prevent unauthorized personnel from accidental operation or accidents. Please follow these guidelines:

- Set clear markings at the front and rear switch positions of the PCS to prevent accidental closure and accidents.
- Erect warning signs or set up safety warning bands near the operation area.
- After maintenance and repair operations, be sure to check that the front and rear switches of the energy storage converter are in the off position and that there is no power.

# Safety Precautions

## Unpacking Inspection



- Do not install the product if product or accessory damage, rust, or signs of prior use are found upon unpacking.
- If internal water ingress, missing parts, or damaged components are found upon unpacking, do not install the product!
- Carefully check the delivery note. If the delivery note does not match the product name, please contact customer service.

## Storage and Handling



- Rough loading and unloading are prohibited as they may lead to structural deformation, insulation failure, or other hidden dangers.
- Prepare for weight-bearing during handling to avoid injury from being crushed or twisted by heavy objects.
- During handling, the product must not be inverted, tilted, dropped, subjected to mechanical impact, exposed to rain or snow, or submerged in water.
- When handling heavy items, ensure proper weight-bearing preparation to prevent injury from being crushed or twisted.



- When storing and transporting, ensure the external packaging is intact and undamaged, place the package according to the markings, and avoid upside-down, side-lying, standing, or tilted placements. When stacking, follow the stacking requirements on the packaging to prevent any impact or falling that could cause damage.
- Long-term storage can lead to degradation of electrolytic capacitors. Ensure the device is powered on at least once every 6 months for a minimum of 3 hours. The DC input voltage must be gradually raised to 800V~900V using a voltage regulator.
- Follow the requirements for unboxing and handling. Any damage caused by mechanical collisions or non-compliant storage conditions is not covered by the warranty.



- When handling the device by hand, wear protective gloves and safety shoes to prevent injury.
- When using a forklift to handle, the forklift should lift from the center position to prevent tipping. Before moving, secure the device with ropes on the forklift, and assign someone to supervise during transportation. If internal water ingress, missing parts, or damaged components are found upon unpacking, do not install the product!
- Choose a transportation method with minimal bumps and tilting.
- During storage, try to pack the product into the original packaging box.

## Installation and Wiring



- All operations must be carried out by qualified and professional electrical technicians who are familiar with the relevant local standards and safety regulations.

- When operating the PCS, use insulated tools, wear personal protective equipment, and ensure personal safety. When handling electronic components, wear electrostatic gloves, wristbands, anti-static clothing, etc., to protect the PCS from electrostatic damage.
- Installation, operation, and maintenance must follow the steps in the manual. Do not modify, add, or change the equipment, and do not alter the installation sequence.
- The wiring sequence must follow the order of installing the ground wire first, then the power cables. Ensure proper grounding of the equipment; otherwise, there is a risk of electric shock!
- Before wiring installation, disconnect all power sources of the equipment. Ensure that the front and rear switches of the PCS are disconnected and de-energized to prevent accidental electric shock.
- Arc welding, cutting, or similar operations on the equipment are prohibited without the company's assessment.
- Use the correct tools and understand the proper method for using them.
- Before installation, ensure the mechanical strength of the installation location can support the equipment weight to avoid mechanical hazards.



#### Warning

- Before installation, carefully read the product user manual and safety precautions.
- After wiring, check all wiring to ensure input/output and phase sequence are correct and normal.
- Use the torque values specified in the manual for terminal screw tightening. Insufficient or excessive torque may cause overheating, damage, or fire hazards.
- Disassembling internal structural parts of the energy storage converter without authorization is strictly prohibited. Prevent screws from accidentally falling causing electric shock hazards.

### Power On and Operation:



#### Danger

- Before powering on, ensure that the product is properly installed, and the wiring is correct and secure.
- Non-professionals are strictly prohibited from operating the product to avoid injury or death risks.
- Do not open the product cabinet door or protection cover, touch any wiring terminals, or dismantle any device or components while the product is powered on or operating, as there is a risk of electric shock!
- Do not block ventilation openings or heat dissipation systems, or cover them with other objects during operation to prevent overheating damage or fire.
- The equipment must not be installed or operated beyond the specified technical limits, as this will affect performance and safety.

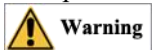

#### Warning

- After wiring and parameter setting, conduct trial operation to ensure the machine operates safely; otherwise, injuries or equipment damage may occur.
- Before powering on, ensure that the battery voltage and grid voltage are within the normal operating range of the PCS to avoid damage to the machine.
- Before powering on, ensure that the minimum battery voltage is greater than the peak line voltage of the grid voltage; otherwise, the machine may fail to operate properly or be damaged.
- During operation, do not touch the equipment enclosure or fans to prevent unnecessary personal injury.

### After Power Off



#### Danger

- Turn off the front and rear switches of the energy storage converter in a timely manner, and ensure the power is off before performing any inspection.
- Wait 20 minutes or use discharge equipment to consume residual voltage, ensuring no internal voltage before touching internal components.

## PCS Maintenance



- Only qualified personnel can perform maintenance on this product. Before performing maintenance, the correct operating procedures must be strictly followed.
- After the power is disconnected, a warning sign should be hung at the disconnection point to prevent accidental power on during maintenance, which may cause safety accidents.
- Internal energy storage capacitors require waiting at least 20 minutes after power-off to ensure zero internal voltage before maintenance. To avoid accidents, maintenance personnel must wear insulated protective gear during maintenance.

# 1 Product Information

## 1.1 Model Description

Models: Mars-125KT-F & Mars-110KT-F & Mars-100KT-F

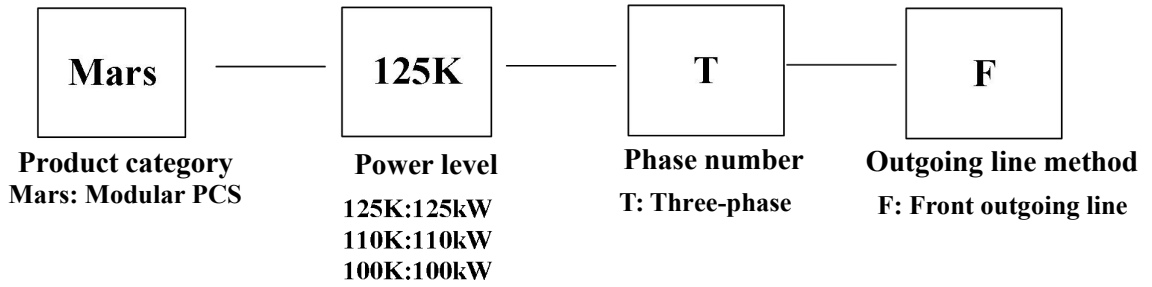

Figure 1-1 Product model description

## 1.2 Introduction to the Energy Storage System

The energy storage system primarily achieves energy conversion between the grid and battery, applicable in generation, transmission, distribution, and consumption stages. It supports peak-shaving, valley-filling arbitrage, demand response, backup power, and disaster recovery modes.

Its main components include energy storage converter, battery, BMS, EMS, as shown in the following figure.

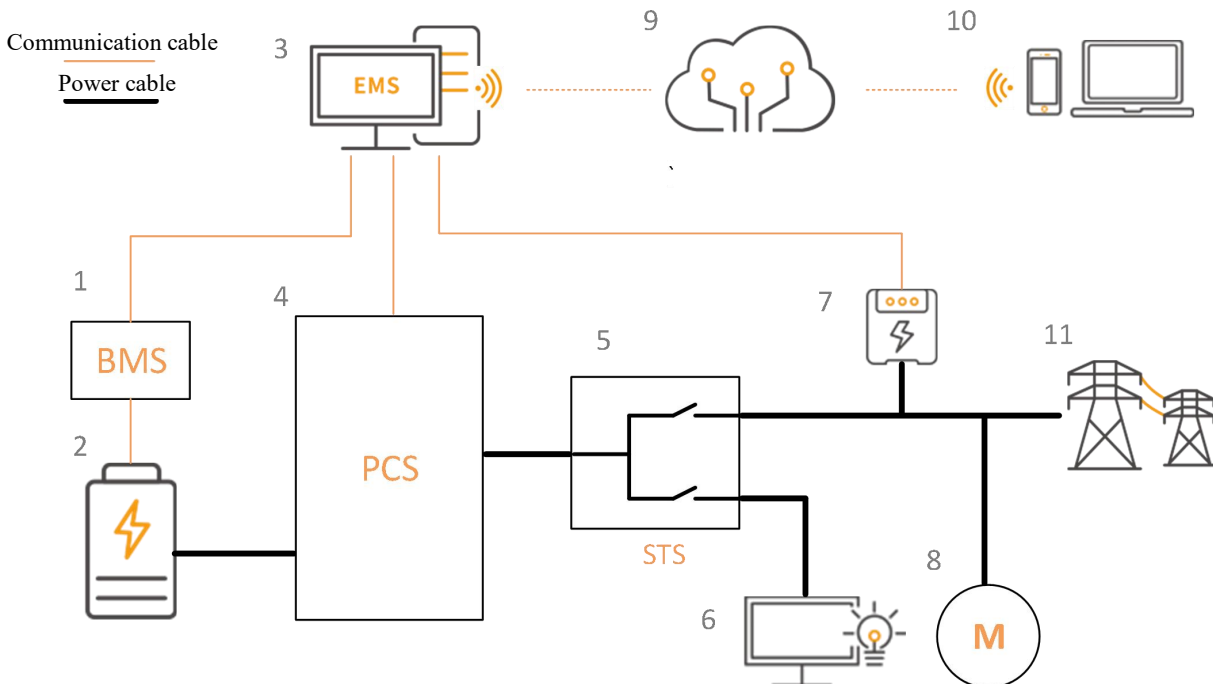

Figure 1-2 Automatic switching between on-grid and off-grid applications

Application scenario for automatic switching between grid-connected and off-grid modes:

When the grid is powered, during off-peak electricity usage, the PCS charges the battery; during peak usage, the battery discharges to the grid via PCS. This achieves peak shaving and valley filling, saving electricity costs.

When the grid power fails, the PCS and STS cooperate to switch to off-grid mode, continuing power supply for critical loads and avoiding losses caused by power outages.

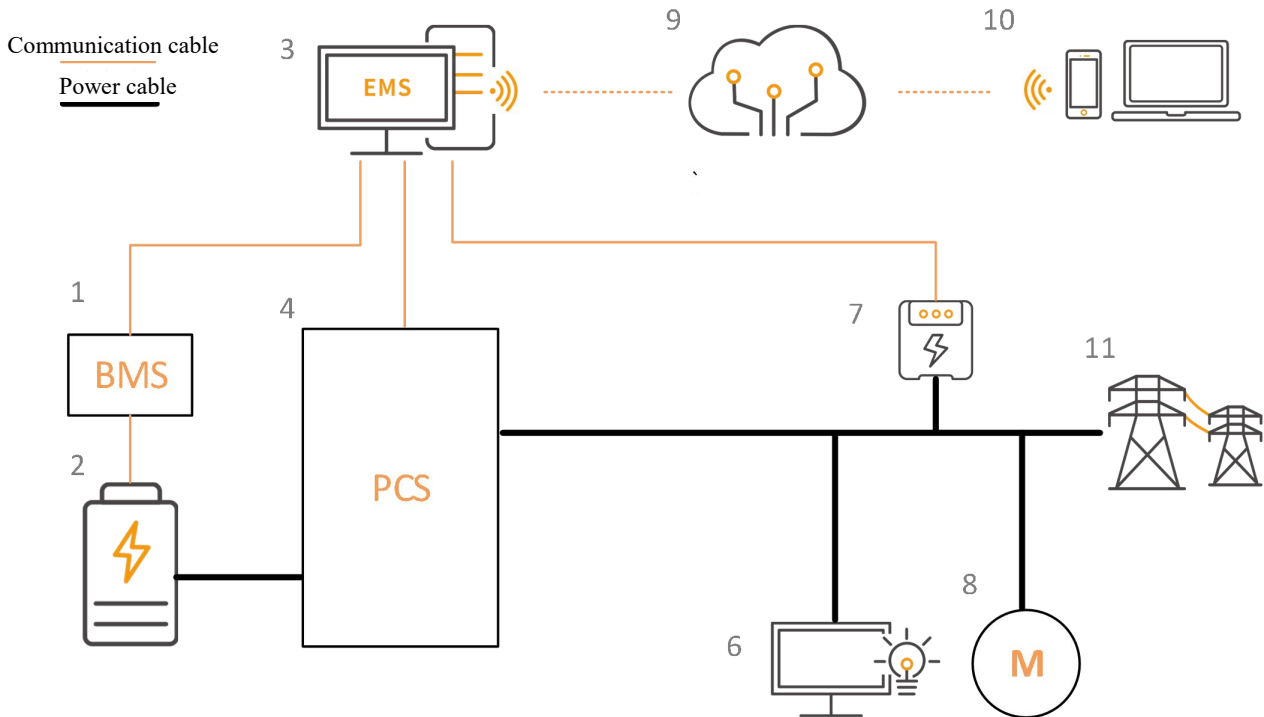

Figure 1-3 Grid-connected application

Grid-connected application:

For scenarios with stable grid or no backup power need, the STS can be omitted to reduce system cost.

Table 1-1 Description of energy storage system components

No.	Name	Description
1	BMS	The battery management system (BMS) is responsible for battery pack management, protection, and monitoring.
2	Battery	Applicable to various types of batteries.
3	EMS	The energy management system (EMS) is responsible for overall system energy scheduling and monitoring.
4	PCS	Responsible for energy conversion between battery and grid.
5	STS	The static transfer switch (STS) is used for automatic switching between grid-connected and off-grid modes; not required for purely grid-connected applications.
6	Critical loads	Loads such as IT equipment and lighting that need to continue operating during grid power outages.
7	Smart meter	Measures the grid-connected point voltage, current, power, etc.
8	Non-critical loads	Loads such as fans and pumps that can stop during grid outages.
9	Cloud platform	Remote monitoring platform.
10	Client	Accesses the cloud platform through mobile APP, PC WEB, etc. to monitor the energy storage system.
11	Grid	In grid-connected mode, the AC side must be connected to the grid.

### 1.3 Principle of the Energy Storage Converter

The energy storage converter uses internal power electronic devices to convert the battery's DC power into AC power to supply other devices (discharging); it can also convert AC power into DC to recharge the battery (charging). The converter can switch between charging and discharging states according to its own configuration or control commands from external devices such as the EMS.

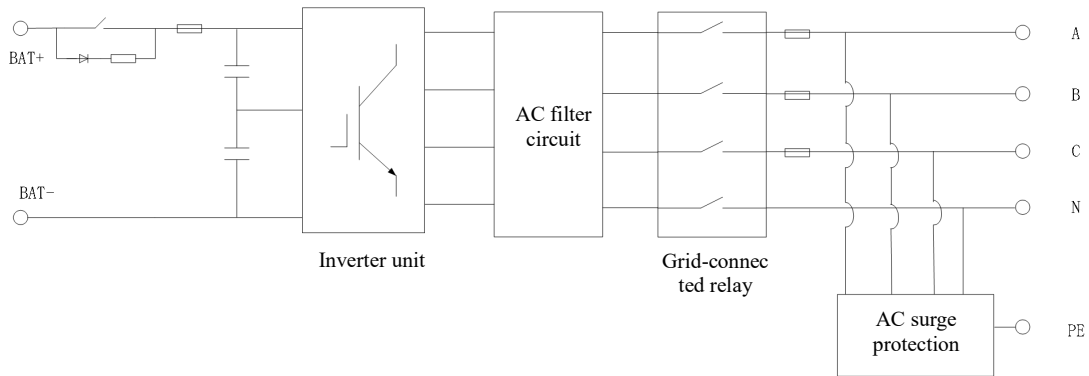

Figure 1-4 Energy storage converter circuit diagram

The PCS is compatible with the following grid types:

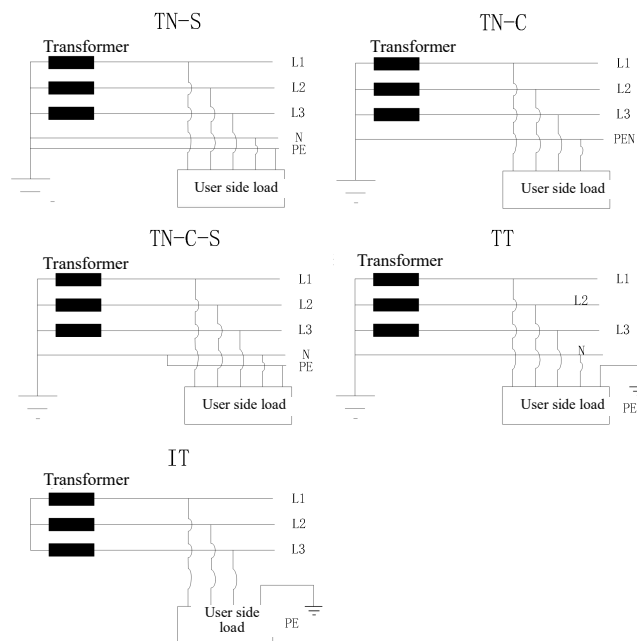

Figure 1-5 PCS grid compatibility

[1] The first letter indicates the relationship between the power source and ground:

T – Power transformer neutral directly grounded.

I – Power transformer neutral not grounded or grounded through high impedance.

[2] The second letter indicates the relationship between the exposed conductive parts of the electrical device and the ground.

T – Exposed conductive parts directly grounded; this grounding point is electrically independent from power source neutral grounding.

N – The exposed conductive parts of the electrical device are directly electrically connected to the power supply's neutral point (grounding point).

## 1.4 Component Description

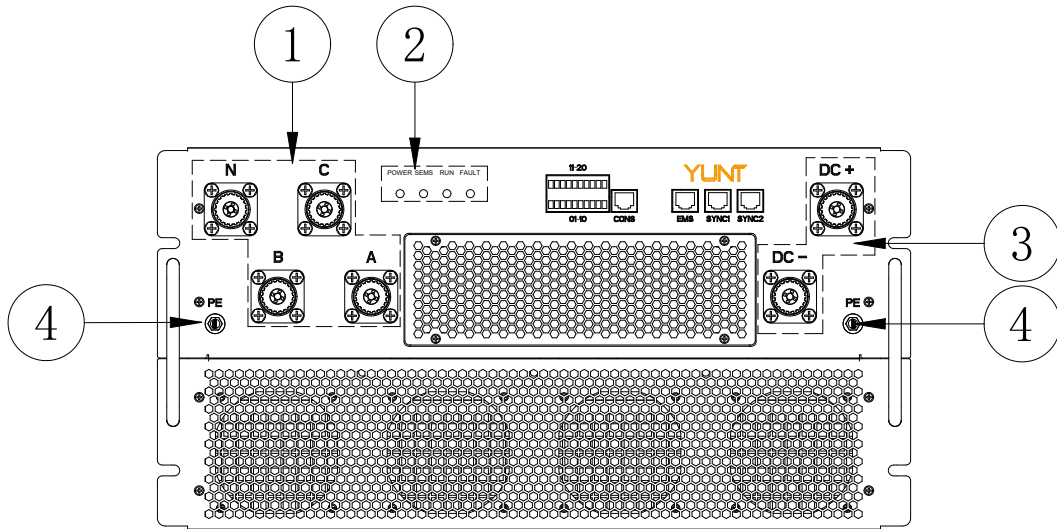

Figure 1-6 Components

Table 1-2 Component description

No.	Description
1	AC terminal block
2	Indicators
3	DC terminal block
4	Ground terminal (M6)

## 1.5 Product Dimensions

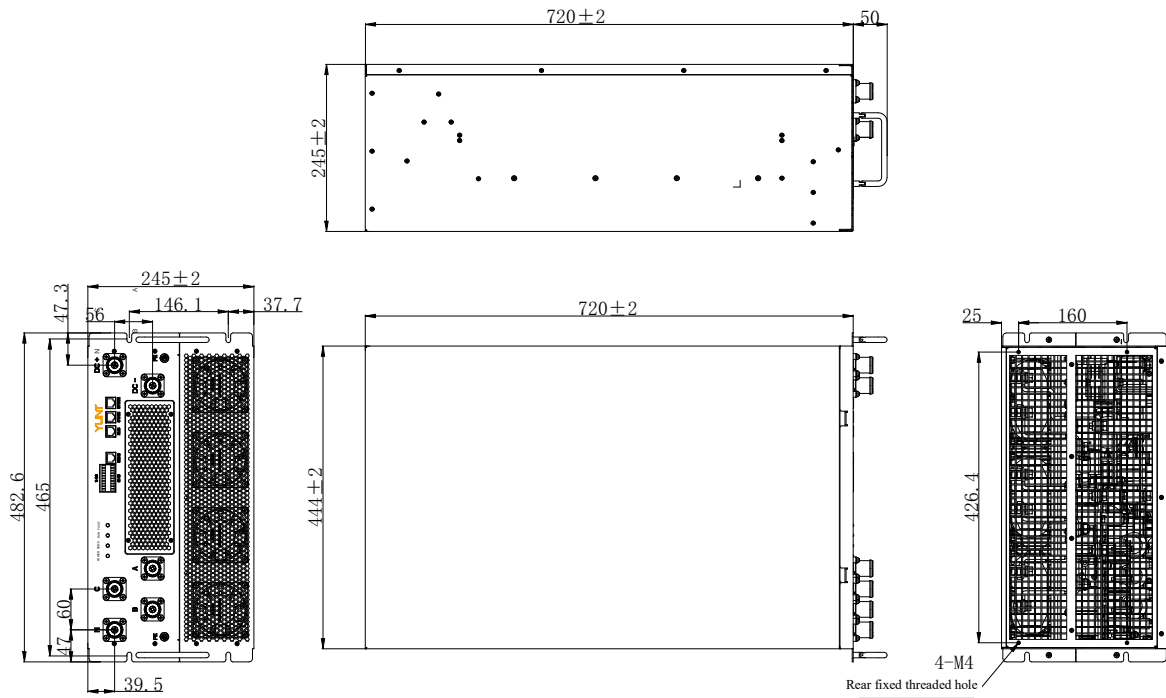

Figure 1-7 Outline dimensions

## 1.6 LED Indicators on the Panel

The front panel of the energy storage converter has indicators. The illustration and definitions of the indicators are shown below.

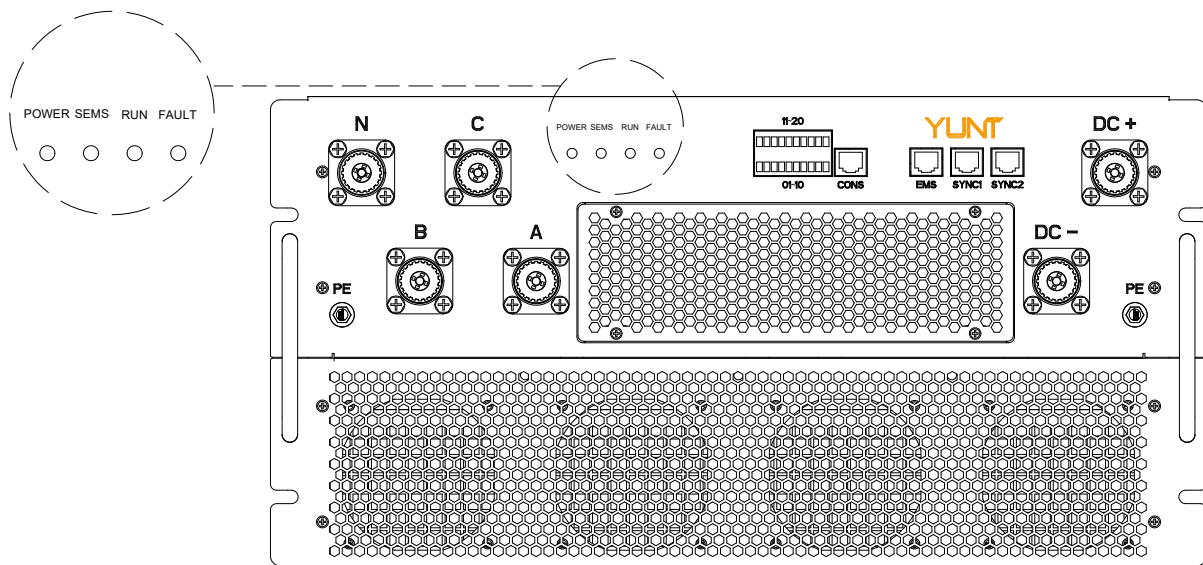

Figure 1-8 Panel LED indicators

Table 1-3 Indicator definitions

Indicators	Status	Description
POWER (green)	Steady on	Both battery and grid connected
	Fast flash <sup>1</sup>	Battery not connected
	Slow blink <sup>1</sup>	Grid not connected
	Off	Both battery and grid not connected
SEMS (green)	Fast blink	Normal communication
	Off	Communication fault
RUN (green)	Off	PCS in shutdown state [2]
	Steady on	PCS in standby state [3]
	Fast blink	Indicates that the PCS is in running state.
FAULT (red indicator)	Slow blink	Alarm
	Steady on	Fault and shutdown status

[1] Fast blink cycle: 1 second; slow blink cycle: 3 seconds;

[2] Shutdown status: The PCS is powered on but not working;

[3] Standby status: The PCS is connected to the grid and running with 0 kW output.

## 1.7 Technical Specifications

Table 1-4 Technical specifications

Model	Mars-125KT-F	Mars-110KT-F	Mars-100KT-F
<b>DC side parameters</b>			
Maximum DC voltage	1,000 V	1,000 V	1,000 V
Minimum DC voltage <sup>[1]</sup>	580V	580V	580V
DC voltage operating range	580-1000 V	580-1000 V	580-1000 V
Maximum DC current	216A	190A	173A
<b>AC side parameters (grid-connected)</b>			
Rated charging/discharging power	125kW	110kW	100kW
Maximum charge and discharge power	150kW	132kW	120kW
Rated charge and discharge current	182A	160A	145A
Maximum charge-discharge current	217A	192A	174A
Rated grid voltage	400V	400V	400V
Permissible grid voltage range	300-460 V	300-460 V	300-460 V
Rated grid frequency	50Hz/60Hz	50Hz/60Hz	50Hz/60Hz
Current total harmonic distortion rate	< 3% (at rated power)	< 3% (at rated power)	< 3% (at rated power)
Power factor	> 0.99	> 0.99	> 0.99
Power factor range	-1~1	-1~1	-1~1

Model	Mars-125KT-F	Mars-110KT-F	Mars-100KT-F
Overload capacity	1.2 Pn, continuous for 1 minute	1.2 Pn, continuous for 1 minute	1.2 Pn, continuous for 1 minute
<b>AC side parameter (off-grid)</b>			
Rated input voltage	400V	400V	400V
Voltage deviation	±2%	±2%	±2%
Voltage total harmonic distortion rate	<3% (linear load)	<3% (linear load)	<3% (linear load)
<b>Efficiency</b>			
Maximum efficiency	98.9%	98.9%	98.9%
<b>Protection</b>			
DC reverse polarity protection	Supported	Supported	Supported
AC short-circuit protection	Supported	Supported	Supported
AC output overcurrent protection	Supported	Supported	Supported
Surge protection	Level 2	Level 2	Level 2
Insulation resistance monitoring	Supported	Supported	Supported
Temperature protection	Supported	Supported	Supported
<b>Basic parameters</b>			
Dimensions (H*W*D)	245 mm (H) x 444 mm (W) x 720 mm (D), excluding terminals	245 mm (H) x 444 mm (W) x 720 mm (D), excluding terminals	245 mm (H) x 444 mm (W) x 720 mm (D), excluding terminals
Weight	≤ 62 kg	≤ 62 kg	≤ 62 kg
Topology	Without transformer	Without transformer	Without transformer
Ambient temperature	-40°C ~ +60°C	-40°C ~ +60°C	-40°C ~ +60°C
Protection level	IP20 (module and battery pack integrated solution, system protection level is IP54 or above)	IP20 (module and battery pack integrated solution, system protection level is IP54 or above)	IP20 (module and battery pack integrated solution, system protection level is IP54 or above)
Operating environment Mechanical conditions	Sine steady-state vibration: 2Hz ≤ f < 9Hz, 1.5mm displacement; 9Hz ≤ f < 200Hz, acceleration 5m/s <sup>2</sup> . GB/T 4798.3-2007 3M2	Sine steady-state vibration: 2Hz ≤ f < 9Hz, 1.5mm displacement; 9Hz ≤ f < 200Hz, acceleration 5m/s <sup>2</sup> . GB/T 4798.3-2007 3M2	Sine steady-state vibration: 2Hz ≤ f < 9Hz, 1.5mm displacement; 9Hz ≤ f < 200Hz, acceleration 5m/s <sup>2</sup> . GB/T 4798.3-2007 3M2
Cooling method	Intelligent air cooling	Intelligent air cooling	Intelligent air cooling
Maximum operating altitude	4,000m (derating when > 3,000m)	4,000m (derating when > 3,000m)	4,000m (derating when > 3,000m)
Standby power consumption	< 12W	< 12W	< 12W
<b>Characteristics</b>			
DC interface	Plug-in terminal	Plug-in terminal	Plug-in terminal
AC port	Plug-in terminal	Plug-in terminal	Plug-in terminal
Display	LED	LED	LED
Communication mode	Ethernet, RS485, CAN	Ethernet, RS485, CAN	Ethernet, RS485, CAN

[1] Minimum DC voltage: For off-grid operation scenarios, the minimum DC voltage requirement is no less than 680 Vdc.

## 1.8 Derating curves (voltage, temperature, altitude)

To ensure safe operation of the PCS and meet local safety requirements, when the operating environment is not ideal, the PCS needs to run at reduced power.

The following are factors that may cause power derating, please try to avoid them during use.

- (1) Derating due to battery voltage being too high or too low;
- (2) Derating due to poor ventilation, direct sunlight, or other factors causing excessive internal temperature of the PCS;
- (3) Derating caused by high installation altitude of the PCS;
- (4) Derating due to grid voltage and frequency.

Voltage derating curve

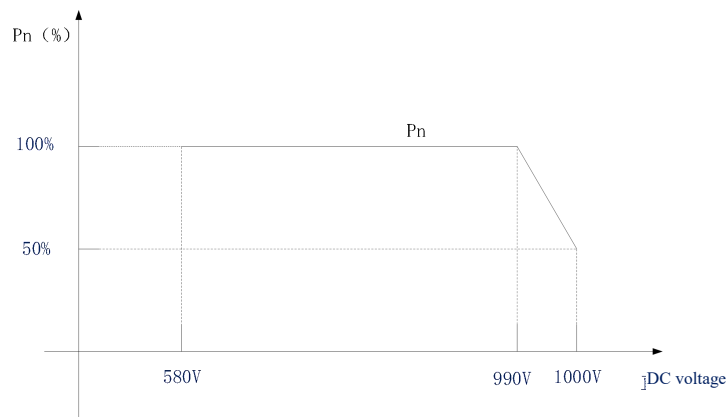

Figure 1-9 Battery voltage power derating curve

Ambient temperature:  $-40^{\circ}\text{C} \sim +60^{\circ}\text{C}$

Temperature derating curve:

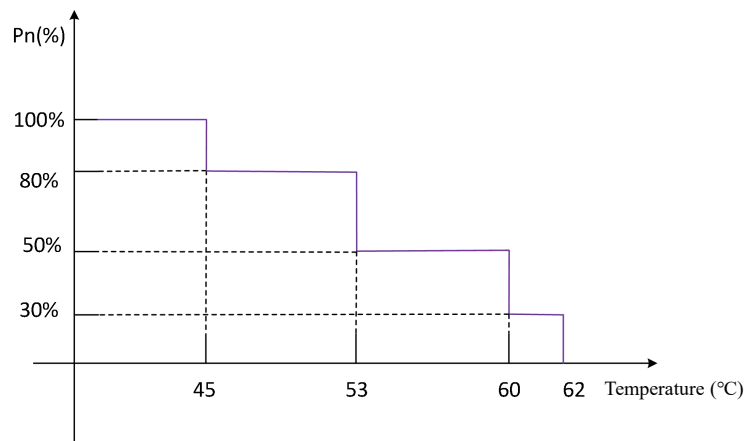

Figure 1-10 Temperature power derating curve

Altitude derating curve:

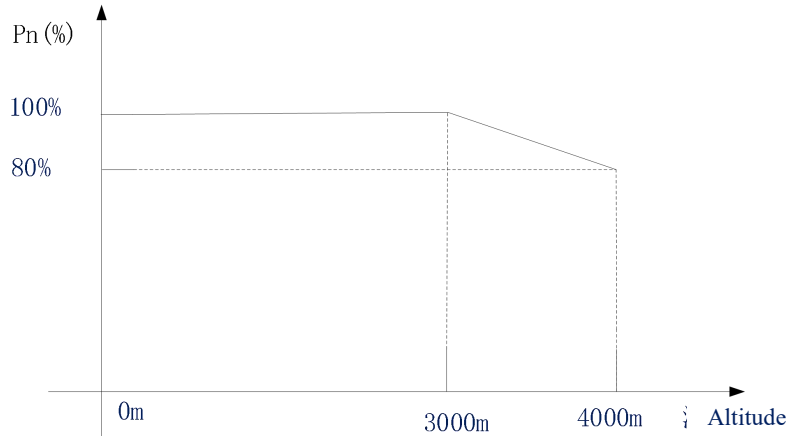

Figure 1-11 Altitude power derating curve

AC voltage derating curve:

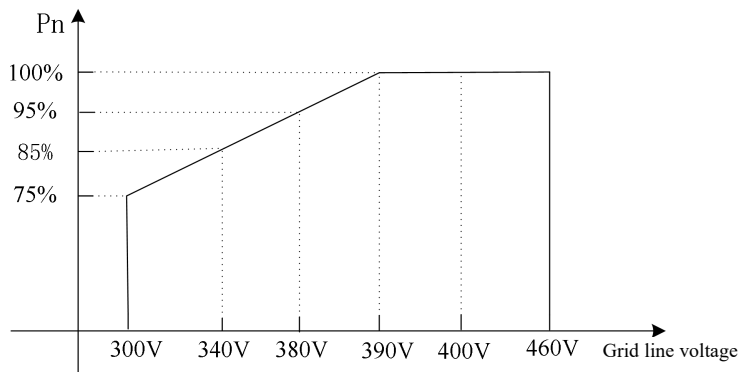

Figure 1-12 AC voltage derating curve

## 1.9 Three-phase Unbalanced Output

The Mars-125KT series PCS uses a three-bridge topology. Although the output is three-phase four-wire, its load-bearing capacity is limited for unbalanced loads. It is recommended that the unbalanced current does not exceed 25% of the rated phase current.



**Attention**

- For high unbalanced load applications, you can select our four-bridge PCS.
- For off-grid load-bearing, considering the larger unbalanced load in off-grid scenarios, it is recommended to add a transformer at the PCS output to make the PCS work in a three-phase three-wire configuration.

## 2 Unpacking and Handling

### 2.1 Transportation and Storage

Pay attention to the markings on the packaging box during transportation and storage. Transportation and storage must meet the following requirements:

- Do not remove the outer packaging of this product;
- No corrosive gases in the surroundings;
- The storage temperature should be maintained between  $-40^{\circ}\text{C} \sim 60^{\circ}\text{C}$ , with environmental temperature variation  $< 1^{\circ}\text{C}/\text{min}$ , and relative humidity between 0%-95% RH;
- Protect from water, moisture, dust, and avoid direct sunlight;
- Regularly inspect during storage, if insect or rodent damage is found, replace packaging materials immediately;
- Comply with fire protection requirements;
- If storage exceeds six months, professional inspection and testing are required before use;



#### Attention

- Avoid transporting this product during rain or adverse weather; if unavoidable, take necessary protective measures.
- During storage, try to pack the product into the original packaging box.
- The equipment must not be left for extended periods in humid, high-temperature, or direct sunlight conditions.
- Equipment damage caused by failure to meet storage conditions is not covered under warranty!



#### Warning

- Long-term storage can lead to the deterioration of electrolytic capacitors. **The product must be powered on at least once within six months**, and the power-on time should be no less than 3 hours. The DC input voltage must be gradually raised to 800-900 V using a voltage regulator.
- If the electrolytic capacitors are not activated due to prolonged storage, resulting in failure of the internal aluminum electrolytic capacitors, it is not covered under warranty!

### 2.2 Unpacking

#### 2.2.1 Precautions for Unpacking



#### Attention

- Energy storage converter packaging must not be removed during storage; remove only before installation.
- Upon receipt from transport company, carefully and thoroughly inspect the product.
- Check each item against the delivery note. Immediately notify the transport company if any items are missing or damaged.
- Dispose or recycle packaging according to local regulations.

#### 2.2.2 Unpacking

Steps for unpacking:

1. Check the integrity of the PCS packaging box to ensure there is no unpacking, compression damage, water soaking, etc.;
2. Open the carton;
3. Remove all filling materials;
4. With the help of multiple people, take out the module, remove the packaging film, and take out the accessories;
5. Observe and ensure there are no signs of damage;

6. Check whether the actual received goods match the delivery list as per Table 2-2.







### 2.2.3 Unpacking Inspection

After unpacking, the following must be inspected:

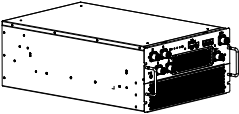
Table 2-1 Unpacking inspection items

No.	Check Item	Completion
1	No damage, scratches, dents on appearance.	<input type="checkbox"/>
2	All ordered items are complete.	<input type="checkbox"/>
3	Nameplate information matches the ordered product model.	<input type="checkbox"/>
4	Warning labels are intact, with no damage, scratches, or blurring.	<input type="checkbox"/>
5	Verify that the received goods match the supply list (see Table 2-2).	<input type="checkbox"/>

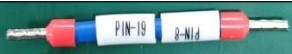
Table 2-2 Delivery list

No.	Name	Image	Remarks
1	PCS		
2	Yellow-green wall terminal		
3	User Manual		If the paper version of the user manual is not received, you can scan the QR code on the machine to obtain the electronic version of the user manual.
4	Parallel connection network cable		
5	Cold-pressed terminal		
6	Emergency stop cable		
7	Power wiring terminals: Orange x 4 pcs Black x 2 pcs		

## 2.3 Handling



- When handling, at least 4 people are needed to lift and move the inverter, or use a hydraulic platform truck and forklift to move the inverter to the appropriate location.
- During handling, keep the height of the PCS as low as possible and avoid large swings. Try to ensure the equipment is moved smoothly.
- Handle gently during lifting and lowering to avoid impact or vibration.
- When moving, ensure the ground is level and free of sharp objects.

## 3 Installation

### 3.1 Installation Environment Requirements

- Environmental requirement: Pollution degree II.
- The PCS must be installed inside the energy storage cabinet. The cabinet should meet the environmental protection requirements in Chapters 5.1, 6.2, and 8.2.3 of the GB/T34120-2023 standard. If applied outdoors, the protection level should reach IP54 or higher. It should not be used in offshore environments, areas near pollution sources, or outdoors with only simple shelter. If used in such environments, the protection level should reach IP65. Otherwise, it may cause product failure. Product function anomalies or component damage caused by unsuitable application environments are not covered by the product warranty. Pollution sources refer to areas within the following radius:
  1. Distance from areas with high salt content in seawater/air (such as oceans, salt factories) is 3700m.
  2. Distance from heavy pollution sources such as metallurgy, coal, mining, thermal power plants is 3000m.
  3. Distance from medium pollution sources such as chemical, rubber, electroplating industries is 2000m.
  4. Distance from light pollution sources such as food, leather, heating boilers is 1000m.

Avoid applications in environments containing corrosive or insulation-damaging substances. If use in such environments is unavoidable, the protection level of the energy storage cabinet must reach IP65; otherwise, product failure may easily occur. Malfunctions or component damage caused by failure to meet environmental requirements are not covered by the product warranty.

- In addition to the above requirements, the following installation requirements must also be observed.
  1. The installation location of this product should have necessary shielding to avoid direct sunlight.
  2. The installation location of this product should have good ventilation to prevent poor heat dissipation from affecting its performance.
  3. Safety warning signs for high temperatures, strong electricity hazards, etc., should be placed around the installation area.
  4. The installation area should be away from flammable, explosive items, and should not have strong electrical interference.
  5. The installation rack or wall should have certain fire resistance and meet fire safety standards.
  6. It is recommended to install this product in areas less sensitive to noise. For installation in sensitive areas (e.g., residential areas, offices, schools), soundproofing measures are recommended.
  7. It is strictly prohibited to install the equipment in environments with dust, smoke, volatile gases, corrosive gases, infrared radiation, organic solvents, or excessive salt.
  8. It is strictly prohibited to install the equipment in environments with metallic conductive dust or ferromagnetic dust.
  9. It is strictly prohibited to install the equipment in areas prone to fungi, mold, or other microorganisms.
  10. The equipment should be installed in areas away from liquids. It is strictly prohibited to install it under water pipes, vents, or other locations prone to condensation. It is also prohibited to install under air conditioning outlets, ventilation openings, or cable windows, to prevent liquid from entering the equipment and causing failure or short-circuit during maintenance.
  12. The installation height should facilitate operation and maintenance, ensuring that the indicators, all labels, and wiring terminals are easily visible and accessible.
  13. Keep away from strong magnetic fields to avoid electromagnetic interference. If there is a radio station or wireless communication equipment below 30 MHz near the installation location, please follow the installation requirements below:

Add a multi-turn ferrite core to the PCS DC input line or AC output line, or add a low-pass EMI filter. The distance between the PCS and radio electromagnetic interference equipment should be more than 30m.

#### 14. Installation Carrier Requirements

The installation carrier must not be made of flammable materials and must have fire resistance. Ensure the installation carrier is strong and reliable enough to support the weight of the PCS.









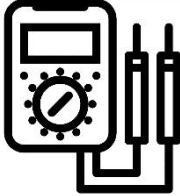
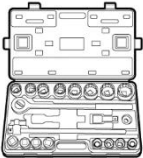
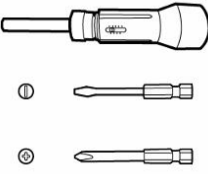

#### Danger

For installation personnel safety, necessary electrical protection measures must be taken during electrical installation. The following procedures must be strictly followed during electrical installation:

- All power connected to the product must be disconnected to ensure no voltage.
- When the system is powered off, it must be left idle for 20 minutes to allow the internal capacitors to discharge before proceeding to the next step.
- Warning signs must be placed at disconnect points to prevent accidental power-on during installation, which could endanger the safety of operators.
- Necessary grounding connections must be made first before proceeding with the next step of wiring to prevent electric shock incidents caused by a charged casing.
- Live components must be properly insulated to prevent harm to personnel.
- Only professional personnel should carry out installation operations, and they must strictly follow the user manual during the process.
- Installers must comply with the relevant electrical operation regulations of the country or region where the installation is taking place.

### 3.2 Installation Tool Requirements

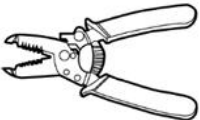
Table 3-1 installation tools list

 <p>Multimeter (Measurement range <math>\geq 1000V</math>)</p>	 <p>Torque wrench</p>	 <p>Torque screwdriver</p>	 <p>Protective goggles</p>
 <p>Cable ties</p>	 <p>Electric screwdriver</p>	 <p>Measuring tape</p>	 <p>Insulated gloves</p>
 <p>Diagonal pliers</p>	 <p>Wire stripper</p>	 <p>Crimping pliers</p>	 <p>Insulated shoes</p>

 **Note**

The table only lists general tools used for wiring installation. Other professional tools should be added or reduced based on the on-site situation by technical personnel.

### 3.3 Use of Modules in the System Cabinet

#### 3.3.1 Installation Methods and Precautions

The PCS can be installed in three ways: left-side vertical, right-side vertical, and horizontal, as shown in the figure below:

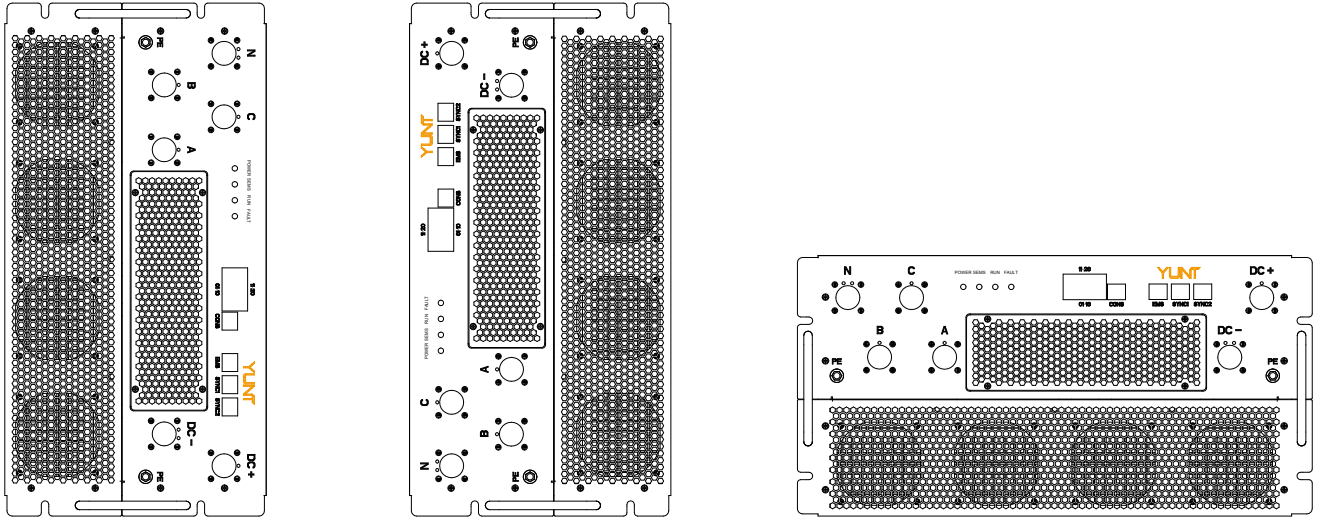

Figure 3-1 Three installation angles of the PCS

The following figure shows two installation methods: horizontal and vertical installations. For duct design, both horizontal and vertical installations require the following considerations:

- (1) It is recommended to add louvers and insect-proof steel mesh with dust cotton at the intake location of the energy storage cabinet. The dust cotton for the intake should be 40~50PPI.
- (2) The recommended distance between the PCS and the dust cotton is 200mm.
- (3) The PCS exhaust outlet should include a 10-mesh insect-proof screen and louvers, and an exhaust fan should be added at the system exhaust outlet (see section 3.3.3 for fan selection).
- (4) The distance between the PCS exhaust outlet and the exhaust fan should be kept between 160mm and 350mm.

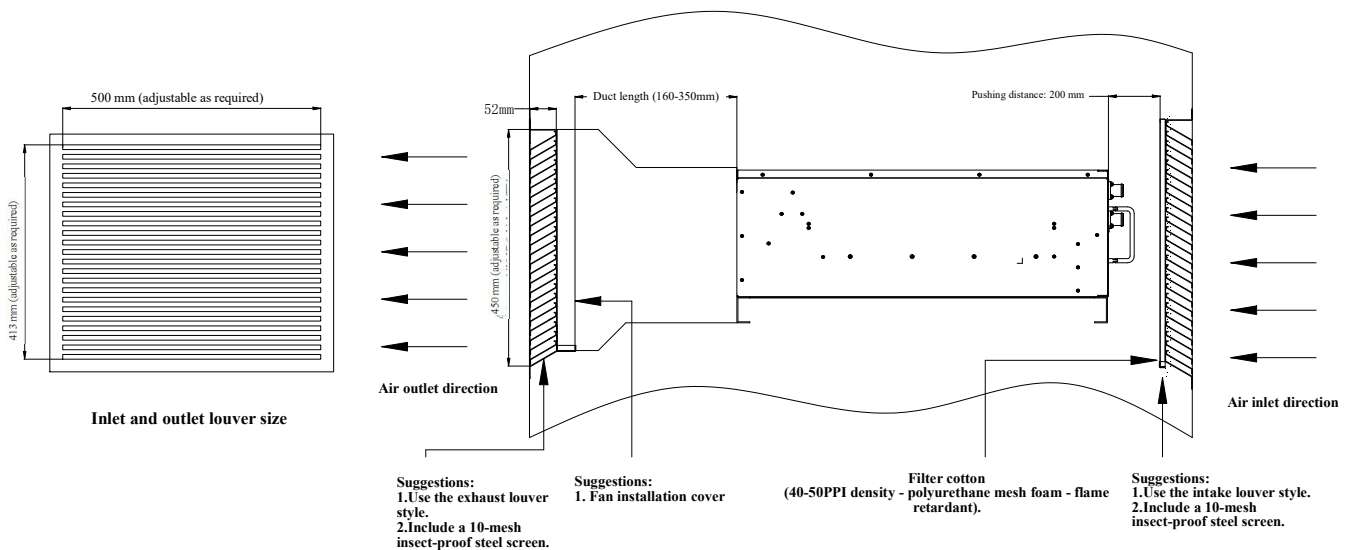

Figure 3-2 Module in the system cabinet A (module placed horizontally).

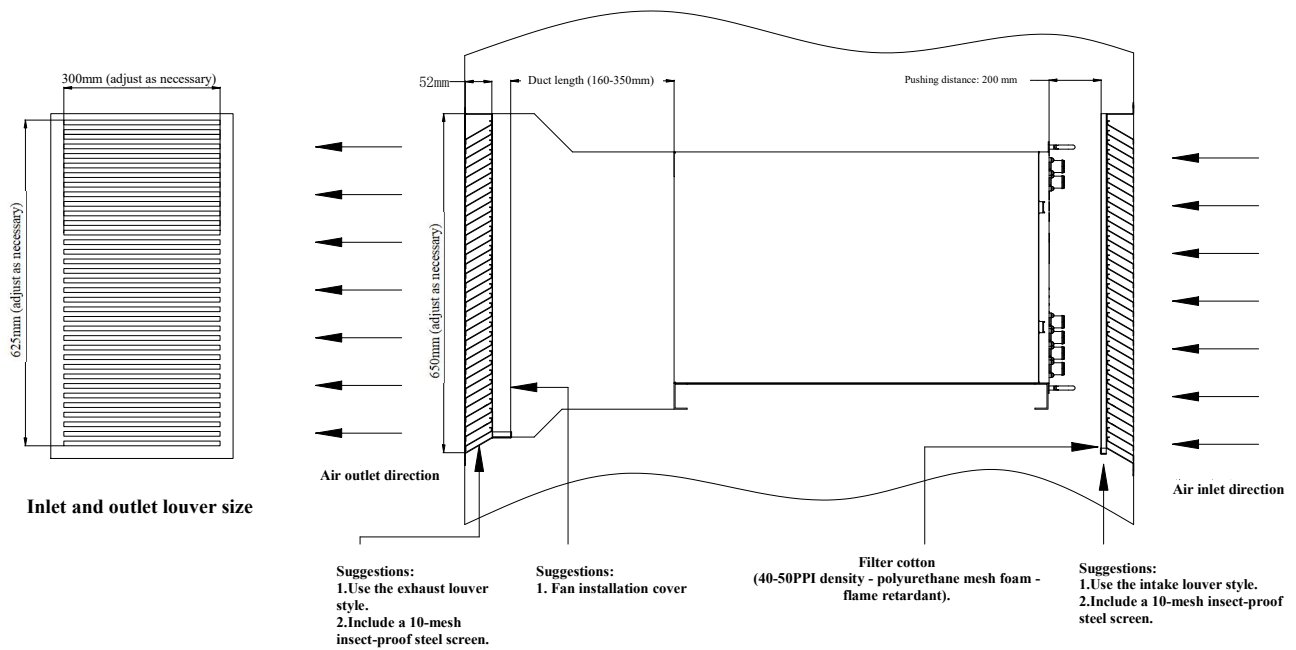

Figure 3-2 Module in the system cabinet B (module placed vertically)



**Warning**

- The PCS is installed in the energy storage cabinet. To prevent the hot air from the PCS exhaust outlet from flowing back to the PCS intake, please install a wind deflector at the exhaust outlet, as shown in the figure below: **the figure only shows the left-side wind deflector, but in actual application, all hot air return paths in the energy storage cabinet need to be cut off.** Adding deflectors before and after the PCS has the same effect. You can choose the wind deflector position according to the actual application.
- When there is a low-resistance airflow path around the PCS, the energy storage system's rear fan will suck cold air directly out of the cabinet through the low-resistance path, causing heat exchange failure. Therefore, a wind deflector must be added to block this low-resistance path.
- The PCS power cables must not block the PCS fan air inlet. Obstruction of the inlet affects cooling, may trigger PCS temperature derating, and can even cause thermal damage. It is recommended that PCS output wiring be routed from the top.

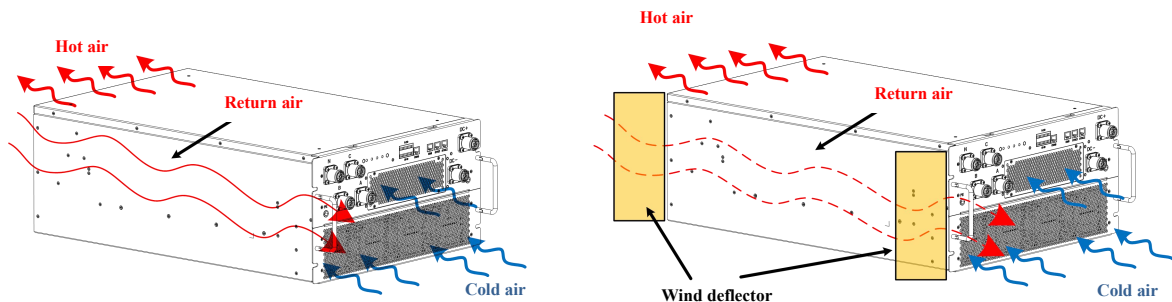

Figure 3-3 Measures for blocking return air and low-resistance paths in the energy storage cabinet.



**Attention**

**The dust filter of the system cabinet, as a part for regular maintenance, must be easily maintainable.**

### 3.3.2 Cabinet Intake and Exhaust Area Design

The intake and exhaust area ensures the proper amount of heat exchange medium. If the intake and exhaust areas are too small, heat exchange will be slow, causing severe heat accumulation in the system, and PCS may derate prematurely. If the intake and exhaust areas are too large, filtering out pollutants will also become an issue.

The following table shows the required inlet/outlet area for the Mars-125KT PCS series. It is recommended that the storage cabinet inlet area be 1.5 to 2.0 times the effective PCS inlet area (especially when the cabinet inlet has resistance from filter cotton, insect screens, louvers, etc.).

Table 3-2 Effective air inlet area of Mars-125KT PCS series.

Product model	PCS effective intake area (m <sup>2</sup> )	PCS effective exhaust area (m <sup>2</sup> )
Mars-100KT	0.05	0.05
Mars-110KT	0.05	0.05
Mars-125KT	0.05	0.05

The "actual effective area" above refers to the area of through-holes.



The calculation of effective intake and exhaust areas for the PCS needs to consider multiple factors, such as the distance between the PCS and the cabinet front and rear, the shape and area of the cabinet door openings, the spacing between louvers and door panels, the system exhaust fan volume, airflow interference, and more. Since each customer's design may differ, precise calculations cannot be made in the user manual. Therefore, after the cabinet design is completed, the thermal testing must be strictly carried out according to the PCS Product Thermal Test Guide for System Cabinets to evaluate the heat dissipation risk.

### 3.3.3 Cabinet Exhaust Fan Selection

1. According to the table below, calculate the total required airflow inside the cabinet for all modules based on the "module cooling airflow."

Table 3-3 Cooling air volume of Mars-125KT PCS modules

Product model	PCS cooling airflow	
	(CFM)	(m <sup>3</sup> /min)
Mars-100KT	433	12.3
Mars-110KT	510	14.4
Mars-125KT	510	14.4

CFM=0.0283 m<sup>3</sup> /min

2. Calculate the maximum airflow for the cabinet exhaust fan.

The maximum airflow value for the cabinet = (1.6 times ~ 2.2 times) \* Actual effective airflow of the module (when the cabinet exhaust is equipped with filtering cotton, insect-proof net, louvers, etc.).

3. Select the fan based on the maximum airflow calculated in step 2.

The following figure shows the specifications for a commonly used fan in the energy storage cabinet, which can be used as a reference. If there are multiple units in parallel, the number of fans should also be increased accordingly.

项目/ITEM		规格.条件/Specification Condition	
01	尺寸系列 / Dimension	206×206×72mm	
02	额定电压 / Rated Voltage	230VAC 50/60Hz	
03	操作电压 / Operating Voltage	220~240VAC 50/60Hz	
04	启动电压 / Start-up Voltage	额定电压 x80% / Rated Voltage x80%	
05	额定电流 / Rated Current ±10%	0.42/0.48A	a. 额定电压 / Rated Voltage b. 25℃ c. 65% RH d. Measured after 5 Mins
06	额定功率 / Rated Power ±10%	87/110W	
07	额定转速 / Rated Speed ±10%	2900/3400RPM	
08	额定风量 / Rated Airflow	980/1200CFM	
09	额定静压 / Rated Static Pressure	1.15/0.78 Inch-H <sub>2</sub> O	a. 标准/Standard : AMCA b. 额定电压/Rated Voltage c. 额定电流/Rated Current
10	寿命预估 / Life Expectancy	60000hrs at 40℃	a.L10 at Conf. Level 90% b.额定电压 / Rated Voltage
11	噪 音 / Noise Level	65/69dB-A	E. 测试条件/ Measure Condition
12	防护处理 / IP level	IP55	
13	马达极数/ No. of Pole	2 极/Poles	
14	电容/ Capacitance	3uF 450V	
15	回转方向 / Rotating Direction	<input checked="" type="checkbox"/> 逆时针/Anti-Clockwise <input type="checkbox"/> 顺时针/Clockwise(从标签面看/From Label Side)	
16	认 证 / Certification	CE/CCC/RoHS	

### 3.4 Installation Steps

The installation steps are as follows:

- One person (using both hands) grabs the handle of the PCS, while another person (using both hands) supports the inverter and inserts it into the corresponding position in the cabinet or uses a lifting vehicle directly.
- Slowly push the PCS completely into the slot.
- Tighten the fixing screws on the front panel of the PCS (four M6\*16 combination screws) and the rear of the chassis (four M4\*12 combination screws), securing it to the cabinet. The installation torque should be 6 N·m for the M6\*16 screws and 1.2 N·m for the M4\*14 screws.
- Install the PCS into the cabinet in sequence, following the order from left to right or top to bottom.

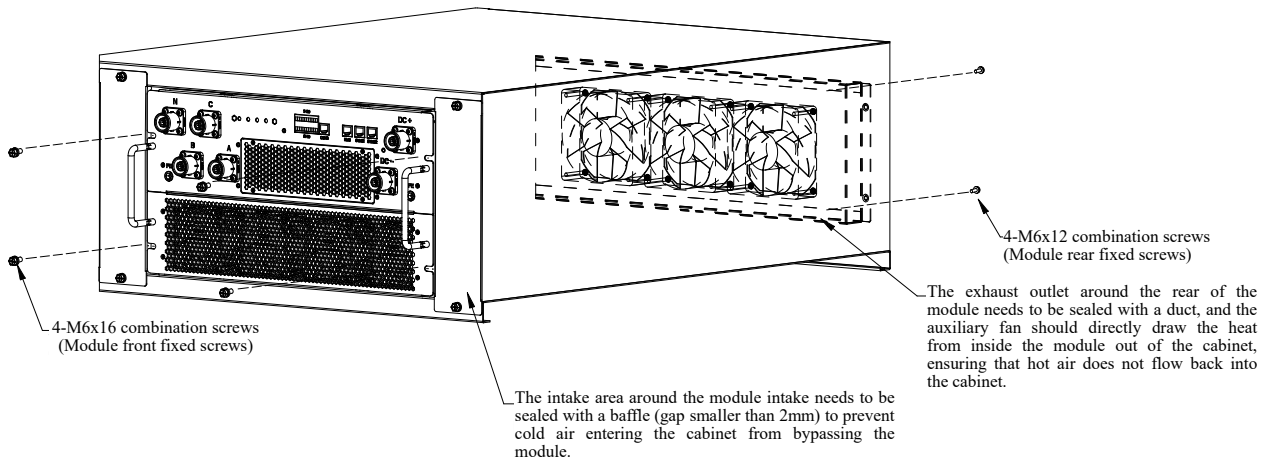

Solution 1: Module horizontal installation diagram

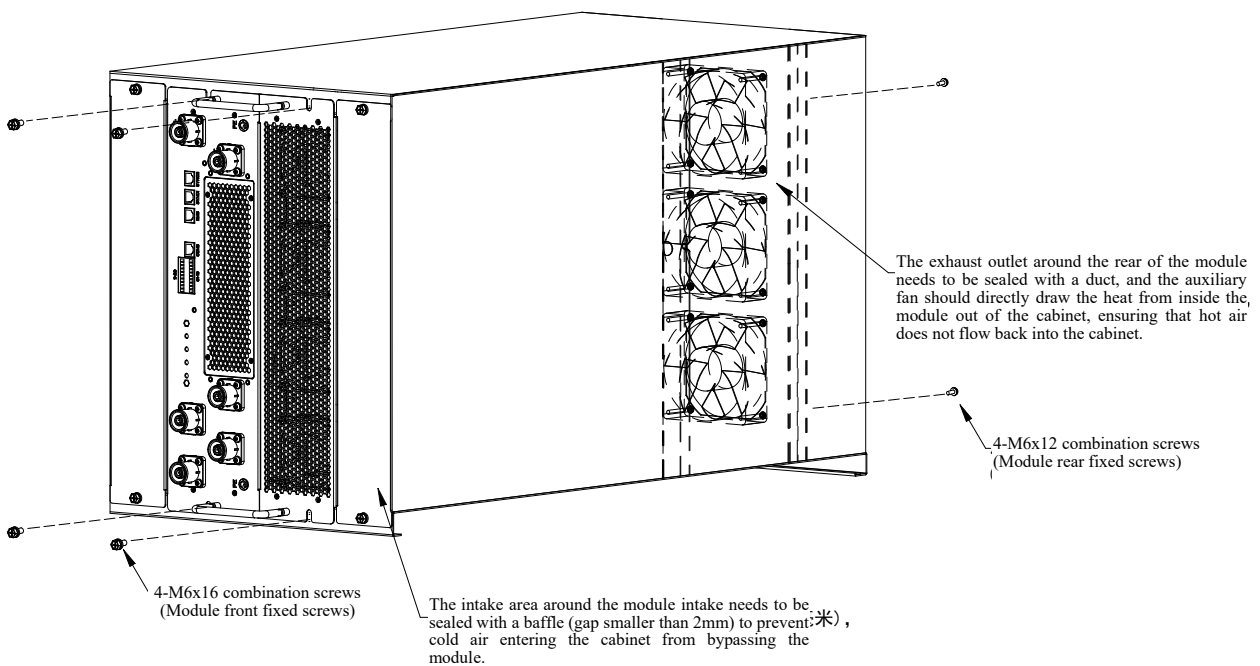

Option 2: Vertical module installation

Figure 3-4 Installation diagram

Notes:

- The intake area around the module intake needs to have baffles added for sealing to prevent airflow from bypassing the PCS and flowing directly to the back of the cabinet via side or low-resistance paths.
- The system cabinet exhaust outlet should have a closed duct to ensure that the auxiliary fan can directly extract the heat from the PCS to the outside of the cabinet, preventing local airflow recirculation.
- The module uses an internal fan for forced air cooling. To ensure sufficient cooling air enters the cabinet, a sufficiently large intake area should be cut out in the cabinet door panel. It is recommended to be 1.5 to 2.0 times the effective intake area of the module (when there are resistance components such as filtering cotton, insect-proof net, louvers, etc., in the cabinet intake).
- When designing the cabinet intake, the airflow should follow the characteristic of cold air expanding when heated, flowing from bottom to top. Therefore, the intake position of the energy storage cabinet should be at least 50mm lower than the intake of the PCS, as shown in Figure 1 and 2.

### 3.5 Cable Preparation

Table 3-4 lists the recommended crimping cable specifications. The power terminal crimping steps are detailed in appendix.

Table 3-4 Cable specifications

Wiring Location	Rated Voltage/Current		Terminal Specifications	Recommended Cable (Minimum)
	Mars-125KT-F	Mars-110KT-F		
DC+	1000V/220A	1000V/190A	Orange terminal (accessory)	70mm <sup>2</sup>
DC-	1000V/220A	1000V/190A	Black terminal (accessory)	70mm <sup>2</sup>
A/B/C	400V/182A	400V/160A	Orange terminal (accessory)	70mm <sup>2</sup>
N	400V/182A	400V/160A	Black terminal (accessory)	70mm <sup>2</sup>
PE	-	-	OT terminal M6	35mm <sup>2</sup>
20PIN signal terminal	-	-	Pin spring terminal crimping terminal	0.5~1mm <sup>2</sup>
SYNC1/SYNC2	-	-	Network port	Category 6 shielded cable
EMS/ETH	-	-		
CONS	-	-		

Wiring Location	Rated Voltage/Current		Terminal Specifications	Recommended Cable (Minimum)
	Mars-100KT-F			
DC+	1000V/175A		Orange terminal (accessory)	50mm <sup>2</sup>
DC-	1000V/175A		Black terminal (accessory)	50mm <sup>2</sup>
A/B/C	400V/145A		Orange terminal (accessory)	50mm <sup>2</sup>
N	400V/145A		Black terminal (accessory)	50mm <sup>2</sup>
PE	-		OT terminal M6	25mm <sup>2</sup>
20PIN signal terminal	-		Pin spring terminal crimping terminal	0.5~1mm <sup>2</sup>
SYNC1/SYNC2	-		Network port	Category 6 shielded cable
EMS/ETH	-			
CONS	-			

### 3.6 Notes for wiring



- Before installation, all switches of the PCS and external front-end devices must be disconnected to ensure that all external cables and the internal components of the inverter are powered off.
- After powering down the PCS, it should naturally wait for 20 minutes or use a discharge device to ensure that the internal components are powered off before continuing operation.
- Electrical connections can only be made by professional personnel and must wear personal protective equipment such as safety shoes, protective gloves, and insulated gloves.

- It is strictly prohibited to operate under power; otherwise, there may be a risk of electric shock.
- All operations during electrical connections, as well as the specifications of cables and components used, must comply with local laws and regulations.
- Cables of the same type should be tied together and separated from different types of cables, prohibiting them from being tangled or cross-arranged.
- If the cables bear excessive tension, it may lead to poor connections. Please leave some extra length when connecting the cables to the PCS terminals.
- When crimping wire terminals, ensure that the cable conductor part is fully in contact with the terminal. Do not crimp the cable insulation together with the terminal, as this may cause the equipment to malfunction or, after running, cause heating or damage to the terminal due to an unreliable connection.
- When crimping wire terminals, ensure that all wire cores are fully inserted into the terminal with no exposed parts, ensuring the safety and reliability of the connection.
- The grounding cables must be installed according to the cable sizes recommended in Table 3-4.



**Warning**

- Damage to the equipment due to incorrect wiring is not covered by the equipment warranty.
- Strictly follow the wiring labels of the PCS and the recommended cables in the user manual when making cable connections.



**Attention**

- Permission from the local power authority is required before the system can be connected to the grid.
- Before installing power cables, verify that the cable labels are correct and that the cable terminals have proper insulation protection.
- The selection, installation, and routing of cables must comply with local laws, regulations, and standards.
- During the laying of power cables, do not allow looping or twisting of the cables. If the power cable is too short, replace it. It is strictly prohibited to make joints or solder points in the power cables.
- All cables must be securely connected, well-insulated, and of the correct specifications.
- Cable trays and cable passing holes should have no sharp edges, and the cables must be protected where they pass through pipes or holes to prevent damage from sharp edges, burrs, etc.
- Buried cables must be securely fixed using cable supports and clamps. Cables in backfilled soil should be in close contact with the ground to prevent deformation or damage during backfilling.
- Using cables in high-temperature environments may cause insulation aging or damage. Cables should be kept away from heating elements or heat sources.
- When making cables, ensure they are kept away from equipment to avoid cable debris accidentally entering the equipment, which could cause sparks and potential personal injury.
- The cable colors in the diagrams of this document are for reference only. The specific cable specifications must comply with local regulatory requirements.

### 3.8 Power Terminal Wiring

The module front end has AC busbar terminals (grid side) and DC busbar terminals (battery side), as shown below.

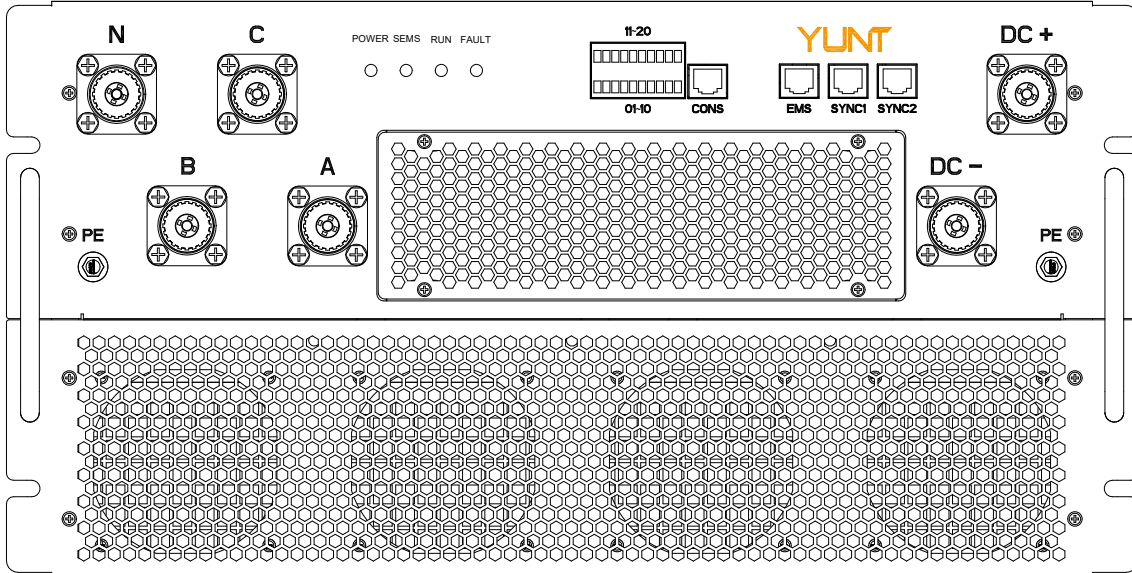

Figure 3-5 Power terminals

Table 3-5 Power terminal definitions

Name	Description	Specifications
DC+	Battery positive	Accessory C-ES09-P70S-02-OR (orange) or Accessory C-ES09-P50S-02-OR (orange)
DC-	Battery negative	Accessory C-ES09-P70S-02-BK (black) or Accessory C-ES09-P50S-02-BK (black)
A	Grid phase A	Accessory C-ES09-P70S-02-OR (orange) or Accessory C-ES09-P50S-02-OR (orange)
B	Grid phase B	Accessory C-ES09-P70S-02-OR (orange) or Accessory C-ES09-P50S-02-OR (orange)
C	Grid phase C	Accessory C-ES09-P70S-02-OR (orange) or Accessory C-ES09-P50S-02-OR (orange)
N	Grid neutral	Accessory C-ES09-P70S-02-BK (black) or Accessory C-ES09-P50S-02-BK (black)

#### DC Side



- Before connecting the battery cables, confirm that both the AC and DC sides of the PCS have been powered off, and that the front and rear switches are both disconnected.
- When the PCS is operating, do not connect or disconnect the battery cables, as improper operation may result in an electric shock hazard.
- When connecting battery cables, use insulated tools to prevent accidental electric shock or short circuits.

 **Warning**

- Ensure that cable connections are tight and well-insulated.
- Use a multimeter to measure the positive and negative terminals of the DC cable, ensuring correct polarity and that the voltage is within the allowable range.
- The PCS supports connecting various battery models. When selecting battery cables, ensure they are compatible with the PCS DC cable requirements.
- Ensure the open-circuit voltage of the battery is within the allowable range for the PCS.

 **Attention**

- The PCS and battery must be equipped with isolation switches (refer to Table 3-6) and current-limiting protection devices. It is recommended to equip circuit breakers or equivalent devices with a current rating greater than 250A. If the battery has switches and current-limiting devices, the decision to equip the switch can be made according to local laws and regulations.
- All electrical installations must comply with the distribution standards of the country/region of installation.
- After tightening the wiring, do not pull the cables horizontally, as this may cause damage to the wiring terminals.

### AC Side

 **Warning**

- Ensure that the cable connections are tight; otherwise, overheating of the wiring terminals during operation may cause equipment damage.
- All electrical installations must comply with the distribution standards of the country/region of installation.

 **Attention**

- Isolation switches and current-limiting protection devices must be installed between the PCS and the grid. It is recommended to equip with a 250 A circuit breaker (see Table 3-6) or an equivalent device.
- All electrical installations must comply with the distribution standards of the country/region of installation.

Table 3-6 Recommended specifications of system devices

Circuit breaker type	Recommended specification
DC circuit breaker	$\geq 250A$
AC circuit breaker	$\geq 250A$

### 3.9 Signal Terminal Wiring

 **Attention**

- When connecting communication cables, ensure that the terminal definitions match the equipment completely. The cable routing path should avoid interference sources, such as power cables, to prevent signal reception from being affected.
- For RS485 or CAN communication, to ensure communication quality between the PCS and connected devices (EMS, BMS, etc.), the connected devices themselves or the terminal must be equipped with a 120Ω terminating resistor.
- To ensure smooth communication, RS485 communication must use twisted pair cables, a daisy-chain network topology, and Ethernet communication must use Category 6 shielded cables.
- The PCS is supplied with a network port protective cover. The protective cover must be kept on unused network ports to prevent dust accumulation, which may cause equipment malfunction.

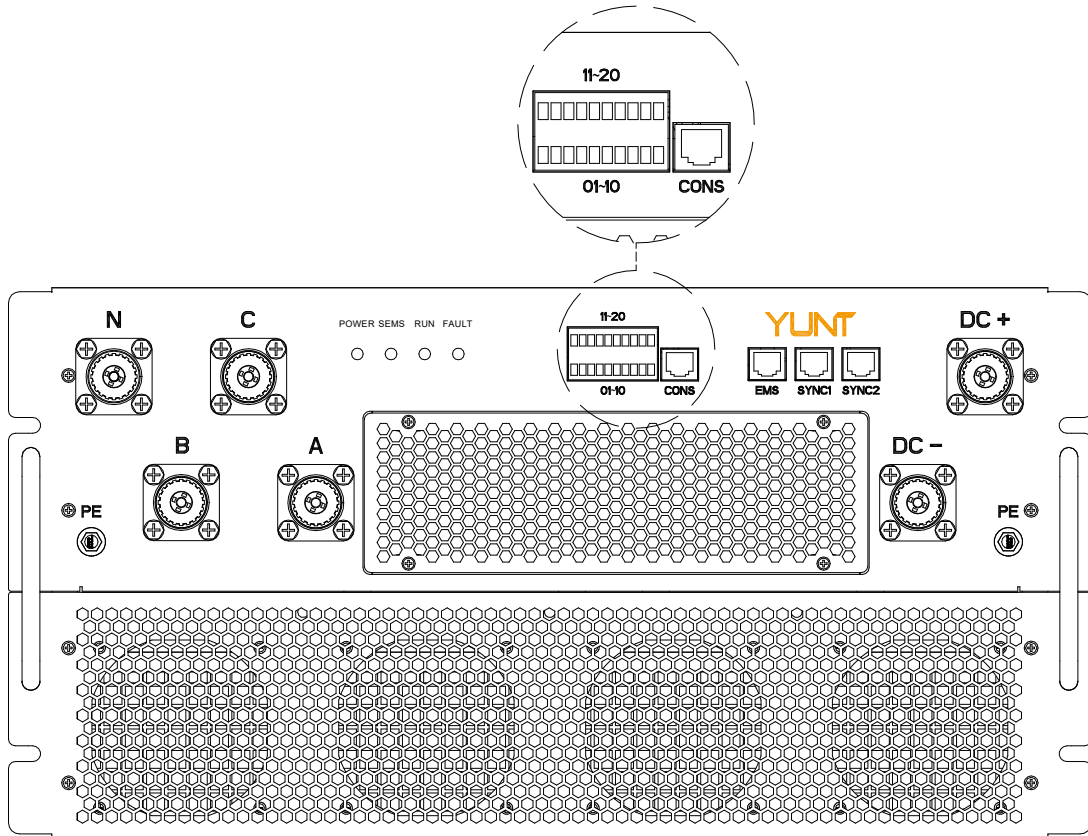

Figure 3-6 Signal terminals

Table 3-7 20PIN signal terminal definitions

PIN	Signal Name	Purpose	Remarks
1	BMS_RS485_A	Connects to BMS; supports Modbus.	Default to 1-to-1 wiring method with 120Ω termination resistor enabled  The communication cable must use twisted pair wiring.
2	BMS_RS485_B		
3	EMS_RS485_A	Connects to EMS; supports Modbus.	
4	EMS_RS485_B		
5	BMS_CAN_H	Connects to BMS; supports CAN2.0.	
6	BMS_CAN_L		
7	VCC_12V	External power supply 12V/5W	
8	IOT_GND	Power ground	
9	Reserved	Reserved	
10	Reserved		
11	DO1_KA	Example: External system fan control	Signal dry contact
12	DO1_KB		
13	DO2_KA	Example: System fault signal light driver	Signal dry contact
14	DO2_KB		
15	DI1_EPO	Example: Emergency stop	
16	DI2	Example: BMS fault	
17	DI3	Reserved	
18	DI4	Reserved	

PIN	Signal Name	Purpose	Remarks
19	DI_GND	DI ground	Users must provide external power supply
20	Reserved		

Table 3-8 RJ45 signal terminal definitions

Interface	Function	Purpose	Remarks
SYNC1	Multi-unit parallel synchronization signal	Daisy chain networking	Use Category 6 shielded cables
SYNC2	Multi-unit parallel synchronization signal		Use Category 6 shielded cables
EMS	Ethernet communication	Connects to EMS; supports Modbus TCP	Use Category 6 shielded cables
CONS	Debug interface	Connect to Smart Assistant	

Note: The emergency stop wiring (usually using normally closed contacts) is shown in the following figure:

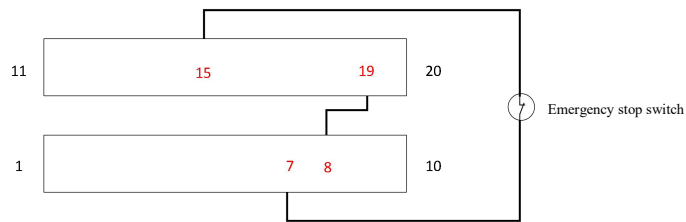

Figure 3-7 Single unit internal power supply emergency stop wiring diagram

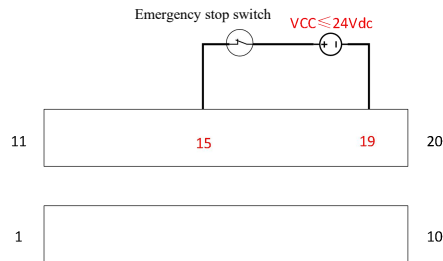

Figure 3-8 Single unit external power supply emergency stop wiring diagram

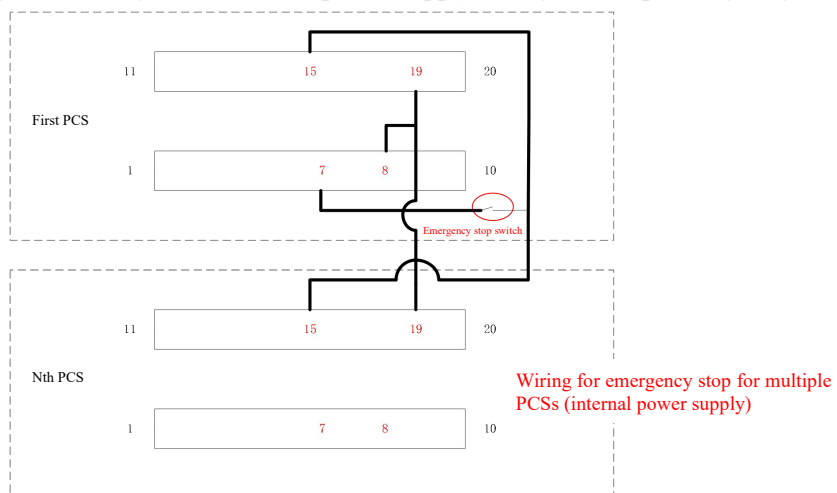

Figure 3-9 Multi-unit parallel internal power supply emergency stop wiring diagram

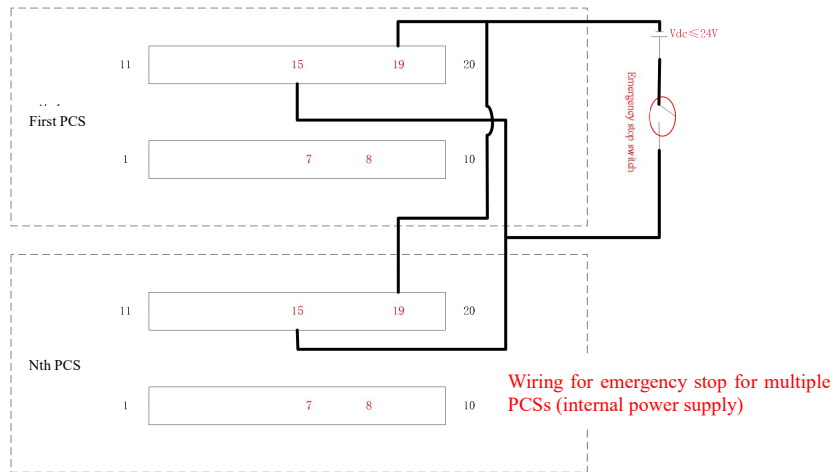

Figure 3-10 Wiring for emergency stop for parallel systems with external power supply



**Attention**

- Emergency stop using internal power supply wiring method is not recommended for multi-unit parallel setups. Internal power emergency stop wiring has the drawback that if the "first PCS" fails and loses power, all parallel PCS units will report emergency stop faults and cannot operate. ! !
- For emergency stop wiring, the PCS default external emergency stop switch is in the normal state when closed, and in emergency stop fault state when the switch is open.

## 4 First Power-On and Operation



- Non-professional personnel are strictly prohibited from powering on and operating the equipment to prevent personal injury and equipment damage!
- Before powering on, ensure that the wiring of the PCS is correct and that the screws are properly tightened.
- After powering on the PCS, personnel are strictly prohibited from touching the inverter to prevent accidental electric shock, burns, and other injuries!
- After the PCS finishes operation and both AC and DC sides are disconnected, it must be left idle for 20 minutes before touching the inverter.



- With all power sources disconnected, ensure effective connection of the energy storage converter's grounding.
- During power-on and power-off operations, a prominent warning label must be placed on the switch to prevent accidental energization by others.

### 4.1 Power-On Guide

Before power-on, check the external power supply is normal; after confirmation, proceed as follows:

1. Disconnect AC and DC power supplies of the energy storage converter.
2. Check AC/DC strong power wiring, emergency stop signal wiring, and EMS communication wiring of the energy storage converter.
3. Connect AC and DC power supplies of the energy storage converter.
4. If no faults are detected, the EMS sends the "power on" command to the energy storage converter.



- The energy storage converter must be powered on strictly following the above startup procedures; otherwise, the converter may be damaged or malfunction.

### 4.2 Power-Off Guide

#### 4.2.1 Normal Shutdown

Normal shutdown steps for the energy storage converter:

1. The EMS sends the "stop" command.
2. The fan runs continuously for 3 minutes to cool the PCS.
3. Disconnect external AC and DC power switches of the energy storage converter.



- After the AC and DC switches are disconnected, wait for 20 minutes before touching the PCS.
- Place warning signs at disconnected switches to prevent accidental re-energizing.

#### 4.2.2 Emergency Shutdown

In an emergency, operate the energy storage converter as follows:

1. Manually press the emergency stop button directly.

2. Disconnect external AC and DC power switches of the energy storage converter.



- Under normal conditions, shutdown is controlled by EMS commands.
- In emergencies, use emergency stop to ensure rapid response and protect equipment and personnel safety.
- After AC and DC power off, wait for 20 minutes before touching the PCS.
- Place warning signs at disconnected switches to prevent accidental re-energizing.

## 5 Maintenance and Troubleshooting

Because the PCS frequently operates outdoors, considering the variable and harsh outdoor environment, device aging may occur during PCS operation. Additionally, vibration may cause power wiring to loosen, resulting in excessive busbar temperature rise. For long-term stable and efficient operation, regular inspection and maintenance become especially important.



The product's input and output are high voltage and high current, posing direct life safety risks. Necessary safety precautions must be taken before maintenance.

- Only qualified personnel can perform maintenance on this product. Before performing maintenance, the correct operating procedures must be strictly followed.
- Before maintenance, ensure DC and AC power supplies are disconnected; verify with a multimeter if necessary.
- After the power is disconnected, a warning sign should be hung at the disconnection point to prevent accidental power on during maintenance, which may cause safety accidents.
- Internal energy storage capacitors require waiting at least 20 minutes after power-off to ensure zero internal voltage before maintenance.
- To avoid accidents, maintenance personnel must wear insulated protective gear during maintenance.



- Shorter maintenance intervals are recommended under severe ambient conditions.
- DC and AC distribution components are more affected by harsh environments; assess maintenance intervals based on site conditions.
- Regular visual inspections are recommended to determine maintenance needs.
- If the product is unused for over 6 months, consult our after-sales engineers or specialists for inspection and testing before use. Non-professionals must perform inspections and tests under the guidance of professionals.
- If the cable is damaged, it must be replaced by a professional to avoid risks.
- It is prohibited to clean the internal and external electrical components of the equipment with water, alcohol, oil, or other solvents.

### 5.1 Daily Inspection

Routine inspection items should be carried out according to the following points:

Table 5-1 Daily inspection checklist

No.	Daily inspection items	Confirmation
1	Monitor input/output voltage, current, and operating status in real time, with dedicated personnel observing fixed points. Maintain timely maintenance upon abnormal operation or abnormal voltage/current.	<input type="checkbox"/>
2	Listen for abnormal sounds from the product.	<input type="checkbox"/>
3	It is recommended to read internal module temperature and verify it is within normal range.	<input type="checkbox"/>

## 5.2 Regular Inspection

To ensure long-term stable operation of the PCS, it is recommended to perform regular inspections according to Table 5-2.

Table 5-2 Regular inspection checklist

No.	Maintenance content	Maintenance method	Maintenance cycle	Confirmation
1	Cleaning the radiator intake and exhaust vents	Check the radiator, intake/exhaust vents for debris or dust. If necessary, the fan can be removed for inspection and cleaning.	Once every six months or once every three months (depending on the local environmental conditions).	<input type="checkbox"/>
2	Fan	Check for abnormal noise from the fan; check for cracks in the fan blades; check for abnormal stalling of the fan; check if the fan has derating protection.	Once every six months	<input type="checkbox"/>
3	Cable connections	Check for aging or damage to the cable insulation. If any issues are found, additional insulation measures or cable replacement is required. Check if the cable connectors are tightened; check if the grounding wire is securely connected.	Once every six months	<input type="checkbox"/>
4	Dust filter condition	Check the dust filter of the cabinet and PCS. If there is severe dust accumulation, replace the dust filter.	Once every six months or once every three months (depending on the local environmental conditions).	<input type="checkbox"/>
5	Network port terminal	Check if the unused network port terminals have dust accumulation or corrosion. Ensure that the network port plugs are properly installed.	Once every six months	<input type="checkbox"/>

## 5.3 Fault List

The Mars-100~125KT-F series energy storage converters – AC/DC integrated products are equipped with comprehensive fault protection functions. In case of a fault, the unit will automatically shut down, and the user can read the relevant fault information through the EMS.

Users can perform preliminary self-checks of faults using the prompt information in the table below, observe fault phenomena, analyze causes, and attempt solutions. Note: Do not open the product during self-test fault handling. If faults persist, please contact your sales channel or YUNT.

Table 5-3 Faults

No.	Fault Name	Possible cause	Solution
1	Grid not energized	External grid switch not closed	Close the external grid switch
2	Battery overvoltage	AC side input voltage too high	Check whether the grid voltage is normal
3	Battery undervoltage	AC side input voltage too low	Check whether the grid voltage is normal
4	Grid over-frequency	AC side input voltage frequency too high	Check whether the grid voltage is normal
5	Grid under-frequency	AC side input voltage frequency too low	Check whether the grid voltage is normal
6	Grid phase sequence error	AC side input voltage phase sequence reversed	Adjust the AC side input voltage phase sequence
7	Grid phase loss	AC single-phase input voltage too low	Check whether the grid voltage is normal
8	Grid voltage imbalance	AC input phase-to-phase voltage difference too high	Check whether the grid voltage is normal

No.	Fault Name	Possible cause	Solution
9	Grid islanding state	AC side input voltage fluctuation	Check whether the grid is disconnected
10	Module hardware overcurrent	AC load too large or impact load	Please contact manufacturer
11	Pulse current limiting exceeded	AC load too large or impact load	Please contact manufacturer
12	Busbar hardware overvoltage	Grid voltage/battery voltage too high	Check the grid/battery status
13	Power failure	Power board supply abnormal	Please contact manufacturer
14	Battery current hardware overcurrent	AC load too large or impact load	Please contact manufacturer
15	BMS communication failure	BMS communication line disconnected	Reconnect the BMS communication line
16	EMS communication failure	EMS communication line disconnected	Reconnect the EMS communication line
17	Slave unit fault	The slave unit reports faults	Troubleshoot the slave unit
18	Carrier synchronization failure	PCS master-slave communication lost	Check whether communication cables are normal
19	Device fault	Master unit fault	Troubleshoot the master unit
20	Master unit communication fault	PCS master-slave communication lost / master unit not powered	Check communication line and power status
21	Slave unit communication fault	PCS master-slave communication lost / slave unit not powered	Check communication line and power status
22	STS communication failure	PCS-STC communication lost / STS not powered	Check communication line and power status
23	Abnormal automatic switching command between grid-connected and off-grid modes	Mode not issued after status switch	EMS issues switched mode command within 5 seconds
24	STS fault	STS fault	Troubleshoot STS faults
25	Precharge timeout	Precharge bus voltage not rising	Please contact manufacturer
26	Bus overvoltage	Grid voltage too high	Check whether the grid voltage is normal
27	Bus undervoltage	Severe AC side overload	Check AC phase-to-phase insulation
28	Positive and negative bus imbalance	AC load imbalance	Check AC load distribution uniformity
29	DC power supply not ready	DC input voltage low	Check DC input voltage status
30	Battery voltage polarity reverse connection detection abnormal	DC side positive/negative voltage reversed	Check DC side wiring polarity correctness
31	Battery overvoltage	DC input voltage too high	Check DC input voltage status
32	Battery undervoltage	DC input voltage too low	Check DC input voltage status
33	Battery overcurrent	AC side overload	Derating operation
34	Module overcurrent	AC side overload	Derating operation
35	Grid-side module current imbalance	AC load imbalance	Check AC load distribution uniformity

No.	Fault Name	Possible cause	Solution
36	Module overheating	Overload operation / fan fault	Please contact manufacturer
37	Capacitor overvoltage	AC side input voltage too high	Check whether the grid voltage is normal
38	Capacitor undervoltage	AC side input voltage too low	Check whether the grid voltage is normal
39	Active power too high	Overload operation	Derating operation
40	Active power reaches limiting value	Overload operation	Derating operation
41	Derating due to overtemperature	Overload operation Fan fault	Please contact manufacturer
42	AC and DC power mismatch	Current sensor fault	Please contact manufacturer
43	Active power deviation large	Current sensor fault	Please contact manufacturer
44	External fan fault	External fan stopped	Please contact manufacturer
45	Emergency stop	Emergency stop switch opened	Reset the emergency stop switch
46	DC-to-ground insulation resistance failure	DC-to-ground insulation resistance abnormal	Please contact manufacturer
47	Internal ambient temperature too high	Internal fan abnormal	Please contact manufacturer
48	AD sampling zero drift too large	Current sampling AD value abnormal	Please contact manufacturer
49	DC main contactor fault	DC main contactor command and status feedback mismatch	Please contact manufacturer
50	Main contactor fault	Main contactor command and status feedback mismatch	Please contact manufacturer
51	BMS fault	The BMS issues the command	Check the BMS
52	Charge termination	BMS current limit	Check the current limiting cause
53	Discharge termination	BMS current limit	Check the current limiting cause

## 6 Appendix

### 6.1 Power Terminal Crimping

Step 1: Select cable according to Table 3-4 specifications; strip 26mm–28mm insulation at the cable end.



Step 2: Insert the sealing ring, sealing ring bushing (if the cable insulation is thick enough to prevent installation of the bushing, this part can be omitted without affecting performance), and tail cover onto the cable.

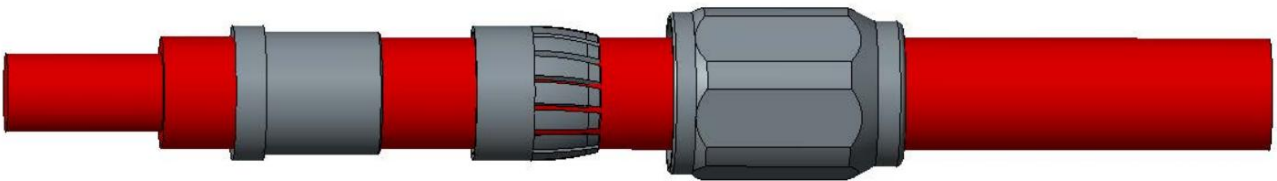

密封圈      密封圈衬套      尾盖  
Sealing ring   seal ring bushing   tail cover

Step 3: Crimp terminal; the recommended harness crimp height is in the table below.

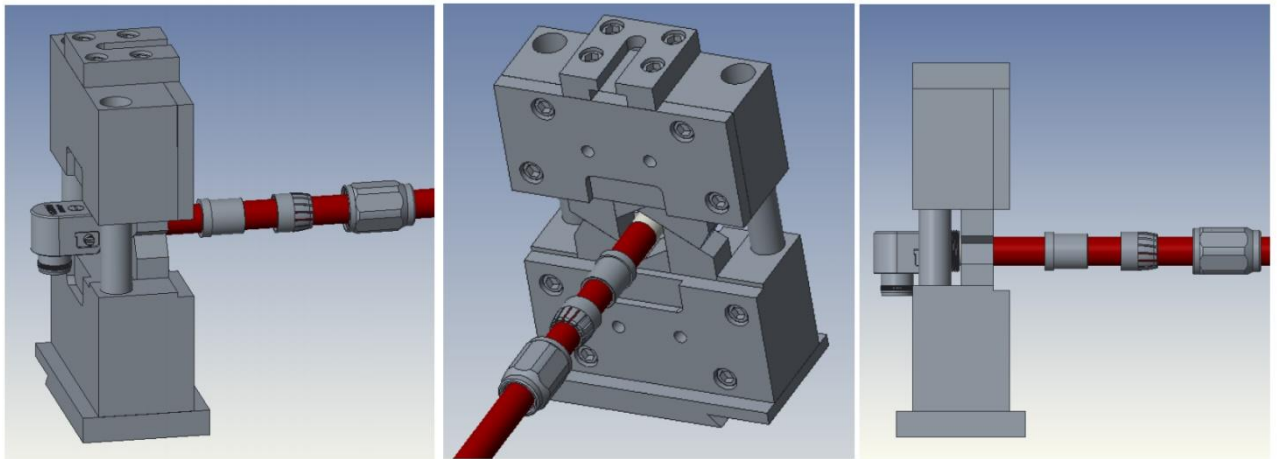

Wire diameter size	D(mm)	E(mm)	F(mm)
4/0	-	-	-
3/0	13.0	7.5	10
2/0	13.5	7.8	10
1/0	14.5	8.4	10
1	-	-	-
2	-	-	-
3	-	-	-
4	-	-	-

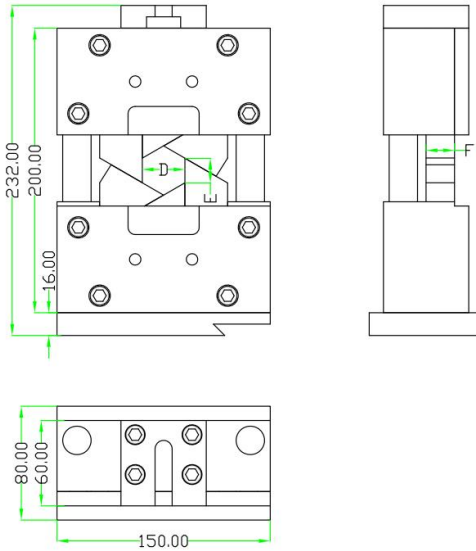

Step 4: Assemble the sealing ring, sealing ring sleeve, and end cover.

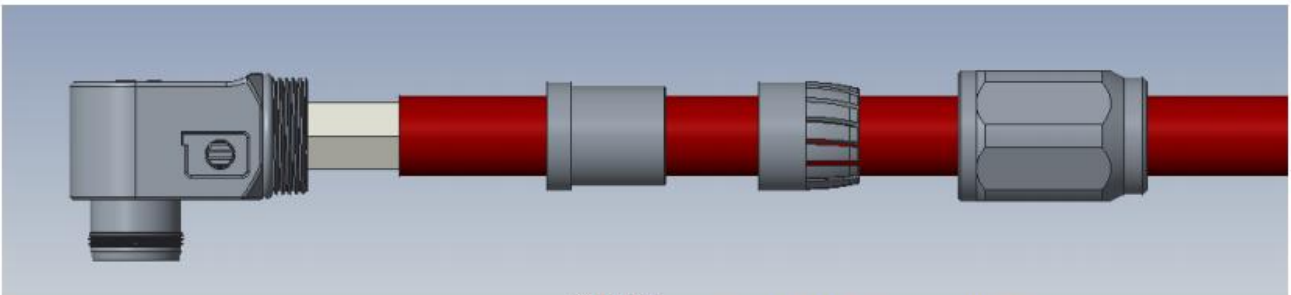

密封圈      密封圈衬套      尾盖  
 Sealing ring   seal ring bushing   tail cover

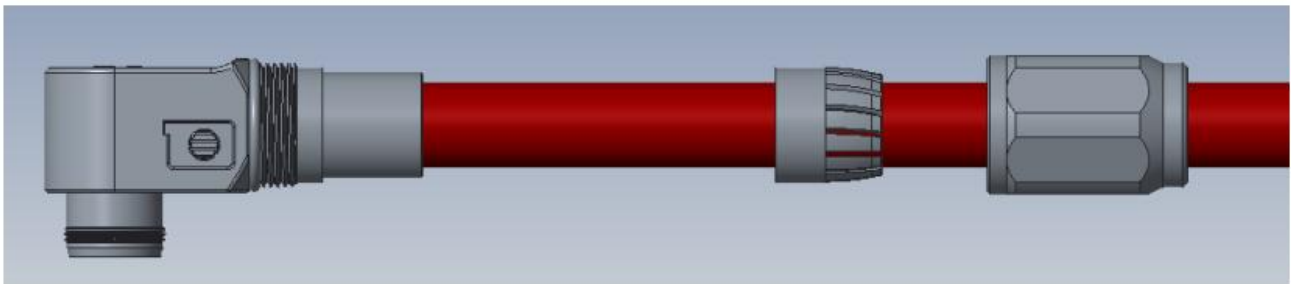

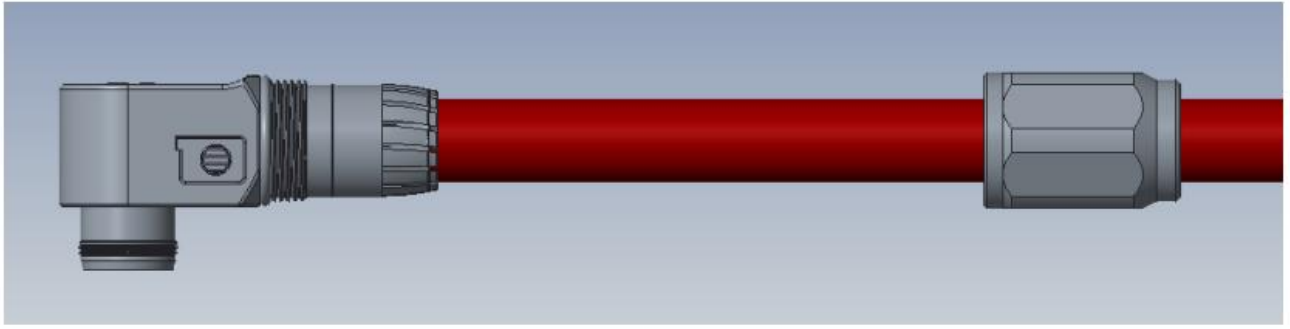

用2.5N.m扭力拧紧尾盖  
Tighten the tail cap with 2.5N.m torque

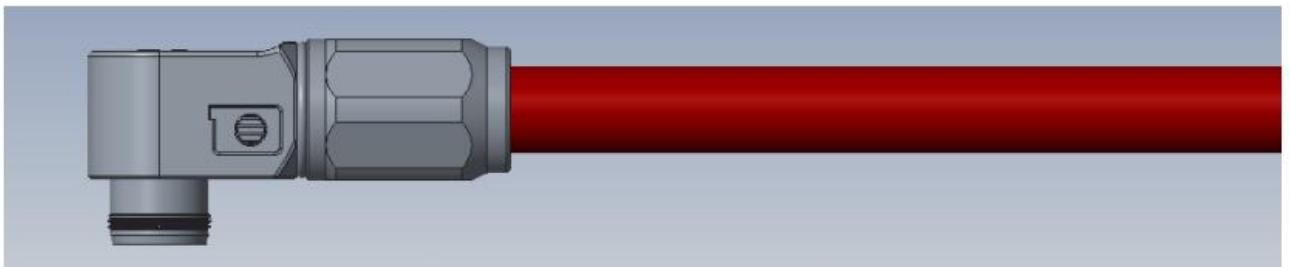





**Shenzhen YUNT Digital Power Co., Ltd.**

Tel: 0755-23592426

Service email: [sales@yunt-power.com](mailto:sales@yunt-power.com)

Website: [www.yunt-power.com](http://www.yunt-power.com)

Address: Building 1, No. 15, Tianbao Road, Shiyan Street, Baoan District, Shenzhen City