

User Manual



Microgrid MPPT Cabinet

Neptune-M Series

120~360kW

V1.0

Copyright © Shenzhen YUNT Digital Power Co., Ltd. All rights reserved.

Without the authorization of Shenzhen YUNT Digital Power Co., Ltd., no content in this manual may be reproduced, transmitted, or uploaded to public networks or third-party platforms in any form.

Trademark authorization



The trademarks and other YUNT Digital Power trademarks used in this manual are owned by Shenzhen YUNT Digital Power Co., Ltd. All other trademarks or registered trademarks mentioned in this manual are owned by their respective owners.

Note

Due to product version upgrades or other reasons, the document content will be updated periodically. Unless otherwise specified, the document content does not replace the safety precautions on the product label. All descriptions in the document are for guidance only.

Warranty Statement

Under normal use, if the product malfunctions or is damaged, YUNT Digital Power will provide warranty service within the warranty period. After the warranty period or in cases where damage is caused by improper operation within the warranty period, repair fees will be charged. For detailed warranty information, please refer to the *Product Warranty Card*.

Contents

1. About this Manual	1
1.1 Product Naming	1
1.2 Applicable Products	1
1.3 Intended Audience	1
1.4 Terminology and Abbreviations	2
1.5 Revision History	2
2. Safety Instructions	3
2.1 Definition of Safety Symbols	3
2.2 Important Safety Tips	3
2.3 Safety Labels	4
3. Product Introduction	5
3.1 Product Overview	5
3.2 MPPT Cabinet Product	6
3.2.1 Product Appearance	6
3.2.2 System Block Diagram	7
3.2.3 Internal Composition	7
3.3 Switches	8
3.4 MPPT Module Indicators	8
4. Transportation and Storage	10
4.1 Transportation	10
4.2 Storage	11
5. Installation	12
5.1 Pre-installation Check	12
5.2 Accessories Inspection	12
5.3 Site Requirements	12
5.4 Foundation Requirements	13
5.5 Installation Space Requirements	13
5.6 Mechanical Installation	14
5.7 Electrical Installation	14
5.8 Grounding Connection	19
5.9 Signal Connection	21
5.10 Pre-operation Inspection	22
6. System Maintenance	23
7. Disposal	24
8. Appendix	25
8.1 Technical Data	25
8.2 Quality Assurance Statement	26
8.3 Contact Information	27

1. About this Manual

This manual describes the Neptune series Microgrid MPPT cabinet in terms of product information, storage and transportation, product installation, electrical connection, and system maintenance. Before installing and operating the Microgrid MPPT cabinet, please carefully read this manual, familiarize yourself with the product functions, features, and precautions. Keep the manual in a place where it can be easily accessed. The content of the manual may be updated periodically. Please refer to the actual product for the latest information. The latest version and other product details can be obtained from YUNT Digital Power’s official website or sales channels.

1.1 Product Naming

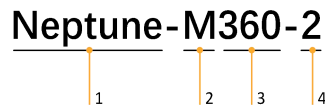

Figure 1-1 Product model naming rules

Label	Example	Description
1	Neptune	Energy routing cabinet product series
2	M	MPPT cabinet
	120	MPPT rated total power: 120kW
	180	MPPT rated total power: 180kW
3	240	MPPT rated total power: 240kW
	300	MPPT rated total power: 300kW
	360	MPPT rated total power: 360kW
4	2	<ul style="list-style-type: none">● By default, blank indicates that the module output port is not paralleled● Numbers 1~4 indicate 1~4 independent DC outputs after parallel connection

1.2 Applicable Products

This manual applies to the following models of Microgrid MPPT cabinets:

- Neptune-M120
- Neptune-M180
- Neptune-M240
- Neptune-M300
- Neptune-M360

The illustrations in this document are for display purposes. If they differ from the actual product, please refer to the actual product.

1.3 Intended Audience

This manual is intended for professional technical personnel responsible for equipment installation,

operation, and maintenance. Professional technical personnel should meet the following requirements:

- Have expertise in electronics, electrical, and mechanical fields, and be familiar with electrical and mechanical schematics.
- Have received professional training related to electrical equipment installation and debugging.
- Be able to respond quickly to emergency situations during installation, operation, and maintenance.
- Be familiar with local standards and safety regulations related to electrical systems.
- Be able to carefully read this manual and understand safety operation instructions related to the following content.

1.4 Terminology and Abbreviations

Terminology and abbreviation	Definition	Functions
MPPT	Max. Power Point Tracking	MPPT is used for tracking the maximum power point in solar power generation, so that the photovoltaic modules can output the maximum power under different light, temperature, and external conditions, thereby improving the efficiency of photovoltaic power generation.
PV	Photovoltaic	Solar photovoltaic panels
BAT	Battery	Battery
EMS	Energy Management System	An energy management system is an intelligent system that integrates hardware and software, used to monitor, control, and optimize the flow of energy and energy consumption in energy systems.

1.5 Revision History





The latest version includes updates from all previous manual versions.

Version: V1.0

2. Safety Instructions

2.1 Definition of Safety Symbols

This manual uses the following symbols to emphasize safety information. Please read the symbols carefully and understand their meanings.

Symbol	Description
 Danger	Indicates a high potential danger that could result in death or serious injury if not avoided.
 Warning	Indicates a moderate potential danger that could result in death or serious injury if not avoided.
 Caution	Indicates a low potential danger that, if not avoided, may result in moderate or minor injury to personnel.
 Attention	Emphasizes and supplements the content, and may also provide usage tips for product optimization to help you solve a problem or save time.

2.2 Important Safety Tips



When operating the equipment, please follow the instructions below to ensure personal safety:

- All electrical connections must comply with local and national electrical standards.
- The copper bars and live terminals inside the equipment may cause fatal electric shocks.
- Before making electrical connections, ensure all powered equipment is de-energized, and the cables are not live. Do not power on before electrical connections are completed to prevent injury and equipment damage.
- Use the correct tools, wear protective equipment, and do not operate while powered to avoid injury and equipment damage.
- After wiring and parameter setting, conduct a trial operation to confirm the machine operates safely. Failure to do so could result in injury or equipment damage.
- Maintenance must be performed by qualified electrical technicians to prevent serious hazards. Damage caused by improper maintenance will not be covered by the warranty.



- Before connecting the photovoltaic string, ensure the electrical specifications such as voltage/power of the photovoltaic string meet the microgrid MPPT cabinet's specifications.
- Before connecting the photovoltaic string, carefully read the user manual of the photovoltaic string to understand the product and its precautions, and strictly follow the operating

requirements.

- Pay attention to the polarity of the DC input, and ensure correct polarity connection.
-



- Before installing, operating, and maintaining the equipment, familiarize yourself with all safety instructions in this document and comply with them.
 - All operations of the equipment must be performed by qualified electrical technicians who are familiar with local standards and electrical system safety regulations.
 - Damage to the equipment or injury to personnel caused by improper installation and use according to the document's requirements is not the responsibility of the equipment manufacturer.
-

2.3 Safety Labels

The cabinet uses the following symbols to emphasize safety information. Please read the symbols carefully and understand their meanings.

Safety icon	Description
	Before operating the equipment, please carefully read the manual.
	High voltage danger. The equipment operates with high voltage. Please be cautious and never operate it while powered on.
	Equipment discharge time. After the equipment is powered off, it may still be charged internally for a period of time. Please wait 5 minutes for the equipment to discharge completely before operating.
	Caution danger. There are dangers during storage, transportation, installation, operation, and maintenance of the equipment that should be noted.
	Burn danger. The surface temperature of the equipment during operation may be high, potentially causing burns.

3. Product Introduction

3.1 Product Overview

The main function of the MPPT cabinet is to track the maximum power point for solar power generation, so that the photovoltaic modules can output the maximum power under different light, temperature, and external conditions, improving the efficiency of photovoltaic power generation. It adopts a modular design internally, allowing for integration of 2 to 6 standard MPPT modules. Its main features include:

- Each module uses SiC-MOS power switching tubes internally, with low loss and high efficiency.
- Each module is configured with 4 independent MPPT inputs.
- Single cabinet is compatible with 2-6 MPPT modules.
- Each module is equipped with an output protection circuit breaker.
- The modular design of the entire cabinet makes maintenance easy.

The internal system schematic of Neptune-M360 is shown in the figure below, with 6 independent outputs as standard. The number of modules can be customized from 2 to 6.

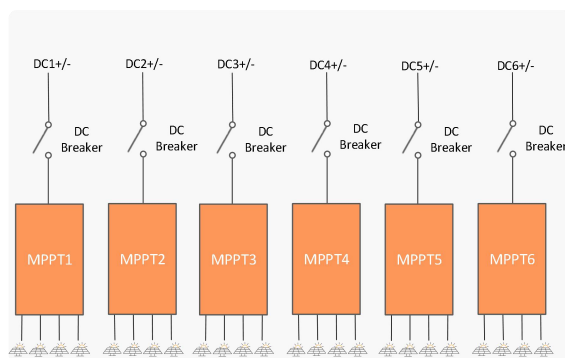

Figure 3-1 System block diagram of the Neptune-M360 cabinet

The product also supports different group outputs. For example, Neptune-M360 can output 1 route (Neptune-M360-1), 2 routes (Neptune-M360-2), and 3 routes (Neptune-M360-3), with the following schematics. Specific requirements can be consulted with YUNT Power Energy.

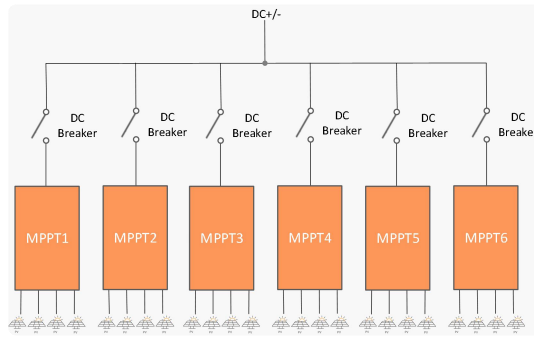

Figure 3-2 System block diagram of the 1-route output MPPT cabinet

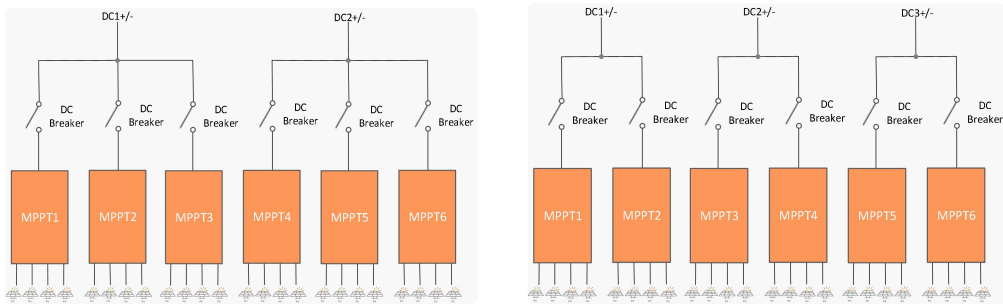

Figure 3-3 System block diagram of the 2-route and 3-route output MPPT cabinet

3.2 MPPT Cabinet Product

3.2.1 Product Appearance

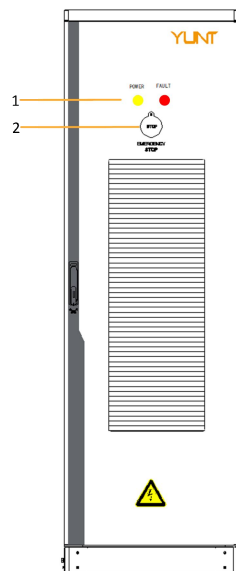

Figure 3-4 MPPT cabinet appearance

Label	Component name	Description
1	Indicators	* POWER (yellow): System power-on indicator * FAULT (red): System emergency stop/fault indicator
2	Emergency stop button	

3.2.2 System Block Diagram

The Neptune-M360 system block diagram is shown below.

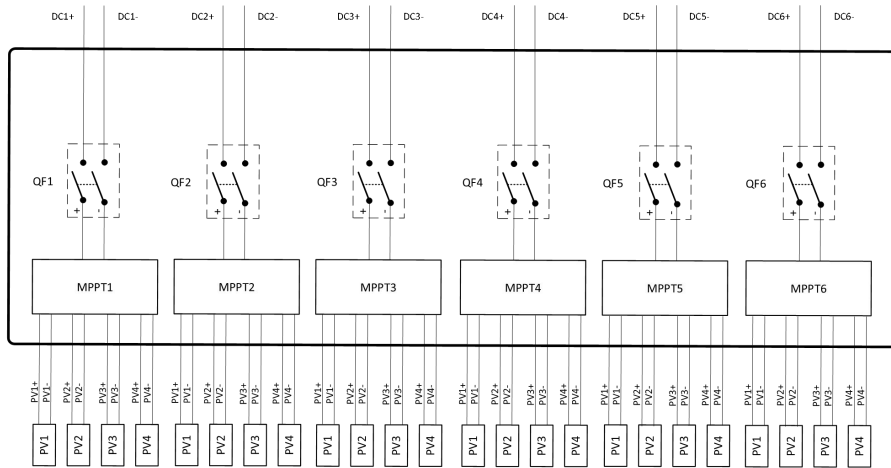

Figure 3-5 6-route output MPPT cabinet system

3.2.3 Internal Composition

The internal structure layout of Neptune-M360 is shown below.

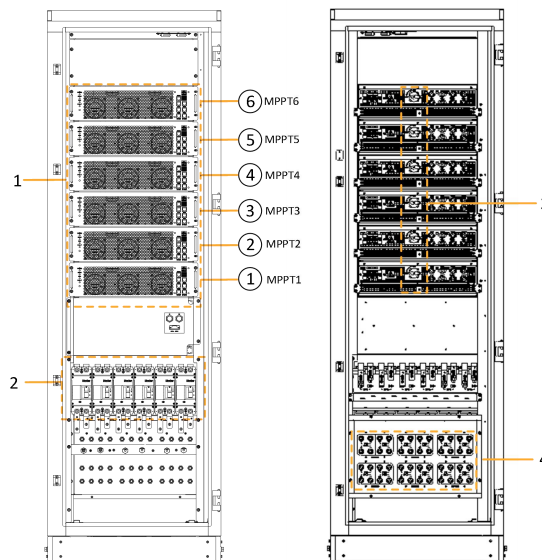

Figure 3-6 MPPT cabinet internal layout

The relevant components indicated in the diagram are described in the table below.

Table 3-1 360KW MPPT cabinet internal components

Label	Component	Description
1	MPPT module	Quantity N=2~6
2	DC output circuit breaker	From left to right, QF6~QF1 correspond to the output control of MPPT6~MPPT1 modules
3	Photovoltaic input isolating switch	
4	PV terminal block	Connects external photovoltaics

Note: The configuration rules for the MPPT rated total power are as follows: 120KW is configured with modules ①-②, 180KW with modules ①-③, 240KW with modules ①-④, 300KW with modules ①-⑤, and 360KW with modules ①-⑥.

3.3 Switches

The DC switch is used for protection between the MPPT module output and the common DC bus, as shown in QF1~QF6 in Figure 3-5.

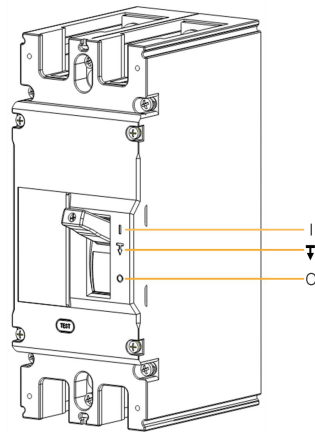

Status symbol	Status	Description
I	Closed	The switch is in the closed state.
T	Tripped	The switch is in the tripped state, and the connection is disconnected.
O	Disconnected	The switch is in the disconnected state, disconnecting the DC power from the microgrid MPPT cabinet.

3.4 MPPT Module Indicators

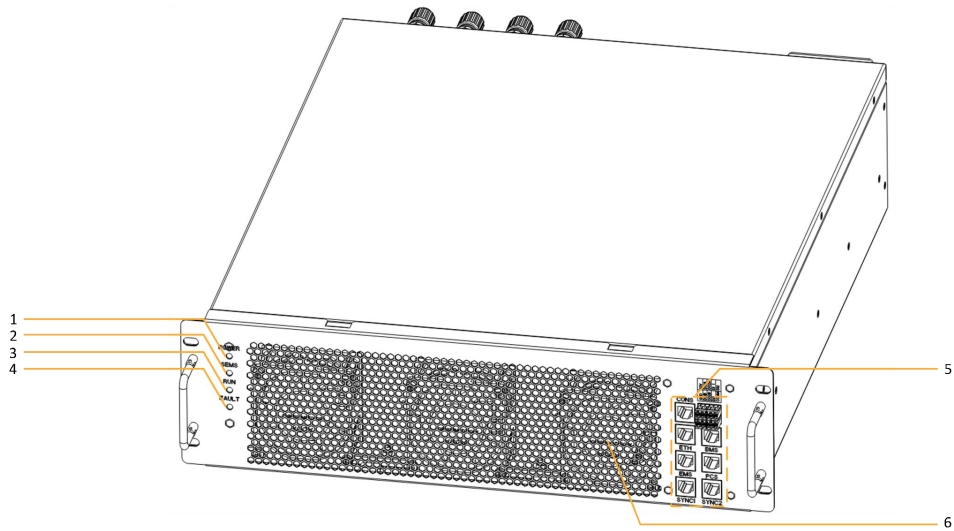

Position No.	Indicating component	Description
1	Power-on indicator POWER (green light)	On: The converter has low-voltage side battery, or PV, or high-voltage side power connected Off: The converter system is not powered
2	EMS communication indicator SEMS (green light)	Blinking: Communication normal Off: Communication abnormal
3	Run indicator RUN (green light)	On: The converter is in operation Off: The converter is not operating.
4	Fault indicator FAULT (red indicator)	On: Converter fault, shutdown state Off: No fault or alarm in the converter
5	Communication port	Communication and debugging between modules and other devices
6	Cooling fan	Module cooling

4. Transportation and Storage

4.1 Transportation

■ Forklift transportation

If the installation site and transport roads are smooth, forklift transportation can be used. When using a forklift, the following requirements must be met:

- Before transportation, ensure the cabinet door is tightly locked, transport under good weather conditions, clear any obstacles on the transport route, and ensure the road is clear. Make sure to evacuate personnel in advance and prohibit unauthorized personnel from entering the transport route.
- At least two people are required for transportation, and the forklift must have adequate load-bearing capacity. Fork leg length must meet equipment requirements. Perform a test adjustment before transportation to ensure the safety and reliability of the tools. The forklift legs should be inserted into the slots at the bottom of the cabinet. Do not transport through any place other than the fork legs.
- During transportation, ensure the cabinet remains balanced and transport at a steady speed. Keep the height variation as low as possible, avoiding large swings. Strive to keep the transportation process smooth.
- Lifting and lowering should be done gently to avoid impact or vibration.
- When moving, ensure the ground is smooth and free of debris, and avoid contact with sharp objects.

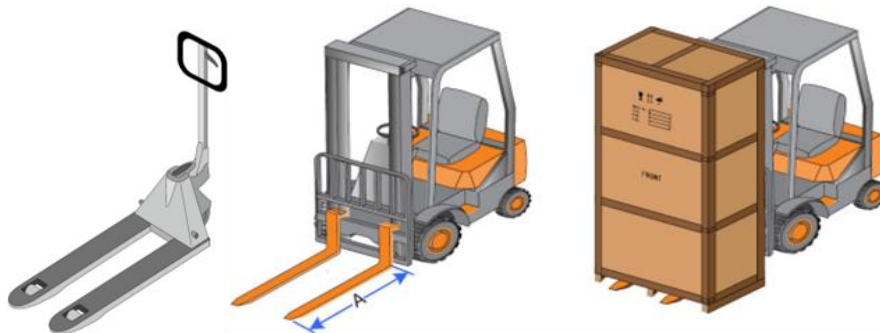

Forklift outer width $\geq 685\text{mm}$

$A \geq 1200\text{mm}$

Load capacity (at least 3t)

■ Lifting transportation

When using lifting for transportation, the following requirements must be met:

- Before transportation, ensure the cabinet door is tightly locked and transport under good weather conditions.
- Evacuate personnel in advance, and prohibit people within 5m-10m of the lifting area and equipment to ensure safety.
- A professional operator must be present for the entire transportation process.
- The lifting straps used must have the strength to bear the equipment's weight.
- Use all necessary auxiliary means to ensure a smooth transportation process. Otherwise, there

may be a risk of the equipment tipping over or falling.

- Perform a test lift before transportation. After lifting 300mm from the support surface, pause for inspection to ensure the lifting straps and connections are secure before proceeding with the lift.
- During lifting, ensure vertical lifting. Do not drag or push the equipment. During lifting, the equipment should be transported at a steady speed, keeping height variation as low as possible. Avoid large swings.
- Lifting and lowering should be done gently to avoid impact or vibration. During lifting and lowering, the cabinet must not pass over people, and no one should remain under it.
- The area where the equipment is placed should be solid, flat, well-drained, and free from obstacles or protruding objects.

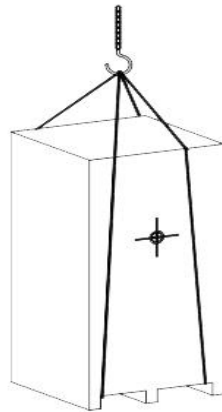

4.2 Storage

If the equipment is not in use, it should meet the following requirements:

- Do not open the outer packaging of the equipment. If the equipment is unpacked, try to repack it in the original packaging box provided by the company.
- The storage location should be clean, dry, and maintain a temperature between -40°C and $+60^{\circ}\text{C}$, with a temperature change of less than 1°C per minute. Prevent corrosion from dust and water vapor.
- Avoid storing in high-temperature, sun-exposed, low-temperature, and humid environments.
- For long-term storage, it is recommended to inspect the equipment every three months, promptly identify any abnormalities, and address them (such as damage to the outer packaging by insects or rodents).
- After long-term storage, the equipment must be inspected by a professional before being put into use again.

5. Installation

5.1 Pre-installation Check

Before installation, carefully check the following:

- Check if the outer packaging is damaged. If there is any damage, deformation, or cracking, it may cause internal damage to the equipment. In such cases, do not open the packaging or sign for it, and contact the distributor.
- Check if the model of the received equipment matches the model ordered. If they do not match, do not open the packaging or sign for it, and contact the distributor.
- Check if the cabinet shell and internal components are intact and undamaged.

5.2 Accessories Inspection

Before signing for receipt, please carefully check the following:

- Check the packing list to ensure all materials are complete and check for any external damage. If there is any issue, do not sign for the delivery and contact the distributor.



When making electrical connections, if the accessories come with dedicated terminal blocks, please be sure to use them. Using incompatible terminal blocks may cause damage to the equipment.

5.3 Site Requirements



- Before installing, operating, and maintaining the equipment, familiarize yourself with all safety instructions in this document and comply with them.
 - All equipment operations must be performed by professional and qualified electrical technicians, who must be familiar with local standards and safety regulations related to electrical systems.
-

The installation environment must meet the following requirements:

- When choosing the installation site, fully consider the local climate, geological conditions (such as stress wave emissions, groundwater level), etc. Avoid installing in environments that are flammable, explosive, corrosive, or prone to mechanical impact or strong magnetic fields. The temperature and humidity in the installation environment should be within the specified range for the equipment, and proper ventilation must be ensured.
- Ensure there are no trees near the installation site to prevent wind from knocking branches down or leaves from blocking the cabinet door or intake.
- The installation site should avoid gas pipelines, water pipes, and other cable pathways to prevent damage to pipes, cables, and the equipment.

- Ensure the installation site is free of debris and leave enough space for future installation, wiring, and maintenance.
- During installation, ensure the equipment's indicators, warning signs, and labels are unobstructed for easy viewing and warnings.
- The equipment generates some noise during operation, so it is recommended to install it in an area that does not disturb the daily life of yourself or others.

5.4 Foundation Requirements



The equipment is quite heavy, so before constructing the foundation, the installation site conditions (mainly geological and environmental conditions) must be thoroughly investigated. Only after this investigation can the foundation design and construction begin.

An unreasonable foundation design may cause significant difficulties or issues with placing the equipment, opening and closing doors, and later operation. Therefore, the foundation must be designed and built according to certain standards to meet mechanical support, cable routing, and future maintenance needs.



Embed grounding units according to the relevant standards of the country/region where the project is located.

5.5 Installation Space Requirements

To ensure better heat dissipation and maintenance of the equipment, it is recommended to leave enough space in front and behind the cabinet at the installation location to ensure the cabinet door can be opened smoothly, with appropriate spacing on the sides for parallel connection processing.

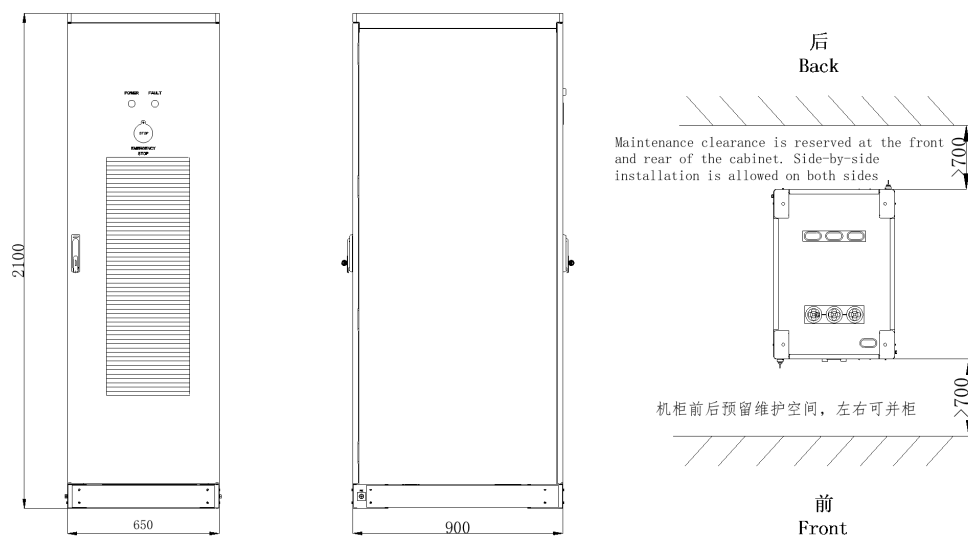

Figure 5-1 MPPT cabinet installation space requirements

5.6 Mechanical Installation

The product installation steps are as follows:

- Ensure that the installation plane of the cabinet is level, and the fixed holes on the installation plane align with the bottom mounting holes of the cabinet. There should be a fixed hole at each of the four corners; refer to the diagram for the fixed hole positions.
- Move the cabinet to the installation location, align the screw holes, and secure the cabinet to the channel steel or foundation using the appropriate bolts.
- The cabinet can also be welded onto the channel steel or the metal floor of a prefabricated warehouse. Be sure to avoid welding damage and take rust prevention measures.
- After installation, apply corrosion protection to the fixed areas.

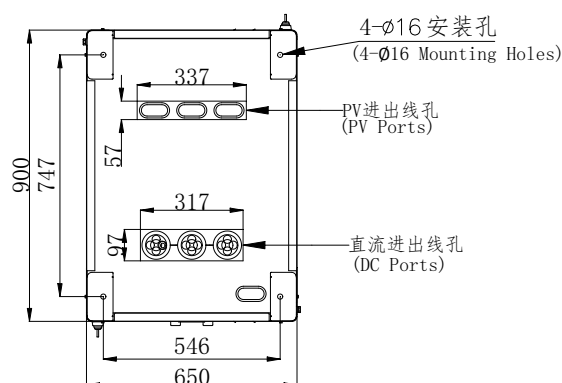

Figure 5-2 MPPT cabinet installation holes

Notes:

- During the handling of the cabinet, it must be done slowly and steadily. When placing the cabinet, ensure that the installation surface is flat and can bear the weight of the cabinet.
- The cabinet must be secured to the installation surface with expansion bolts. Use expansion bolts with appropriate hole sizes, and it is recommended that the bolt protrudes 45mm above the surface.

5.7 Electrical Installation



When making electrical connections, to ensure personal safety, please follow the instructions below:

- It is strictly prohibited for non-professional personnel to install, wire, maintain, inspect, or replace components of the equipment.
- Before making any connections, cut off the power to all equipment and use a multimeter to ensure that there is no power before proceeding. Do not touch powered equipment or perform installations with power on.
- Installers must use the correct tools and wear protective gear to avoid personal injury and damage to the equipment.

- After wiring, check the connections to ensure they are secure and that the phase sequence is correct.



- Choose the connection cables according to the voltage and current levels of the system's power supply and system specifications. Failure to do so may lead to severe electrical failures.

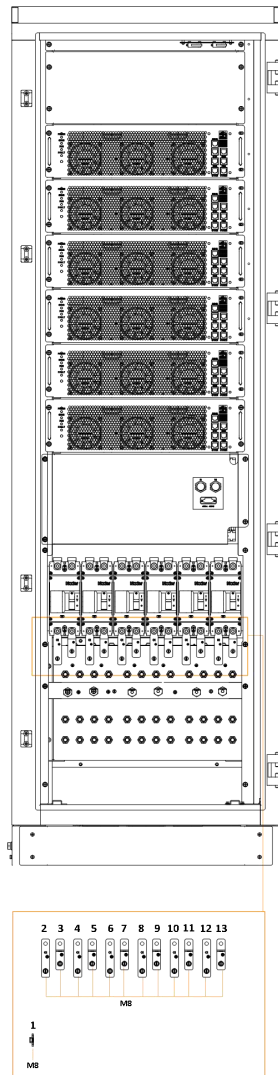

Figure 5-3 MPPT cabinet power front interfaces

The MPPT cabinet power interfaces are defined in the table below.

Table 5-1 6-route output MPPT cabinet power interface definition

Position No.	Name	Description
1	PE	Common grounding interface
2	DC6+	Module MPPT6 positive output interface
3	DC6-	Module MPPT6 negative output interface
4	DC5+	Module MPPT5 positive output interface
5	DC5-	Module MPPT5 negative output interface

6	DC4+	Module MPPT4 positive output interface
7	DC4-	Module MPPT4 negative output interface
8	DC3+	Module MPPT3 positive output interface
9	DC3-	Module MPPT3 negative output interface
10	DC2+	Module MPPT2 positive output interface
11	DC2-	Module MPPT2 negative output interface
12	DC1+	Module MPPT1 positive output interface
13	DC1-	Module MPPT1 negative output interface

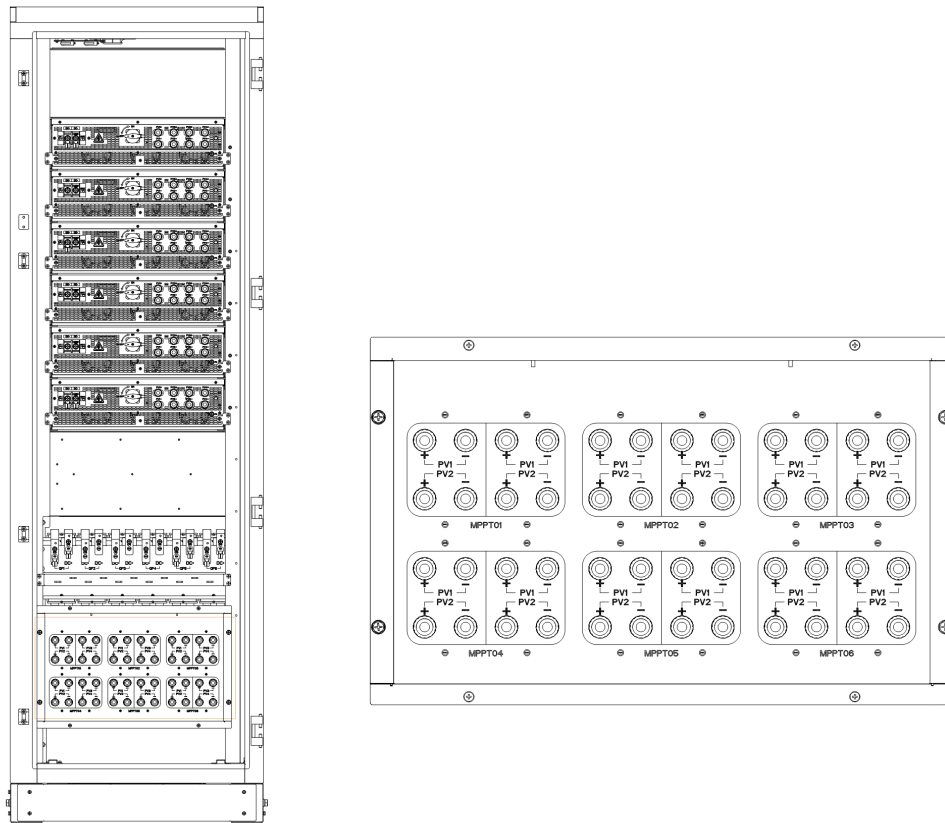

Figure 5-4 MPPT cabinet PV interfaces

The PV input interface of the MPPT cabinet is defined in the table below.

Table 5-2 PV interface terminal definition

PV wiring area	Name	Functions	Wiring description
MPPT01	PV1+	PV1 positive	The MC4 terminal for customer wiring should be connected with the terminals provided in the product accessories, and customers are strictly prohibited from using
MPPT02	PV1-	PV1 negative	
MPPT03	PV2+	PV2 positive	
MPPT04	PV2-	PV2 negative	
MPPT05	PV3+	PV3 positive	

MPPT06	PV3-	PV3 negative	different MC4 terminal models.
	PV4+	PV4 positive	
	PV4-	PV4 negative	

■ Output DC side

Wiring must be performed with the system powered off. Ensure there is no hazardous voltage at any port of the system during wiring. Cables should be labeled, and after wiring, the layout should be clearly visible.



- The positive and negative terminals of the Microgrid MPPT cabinet output must not be reversed. Before wiring, measure with a multimeter.
- Electrically live bolts must be connected with the specified torque. A torque that is too low can reduce the current-carrying capacity of the connection point, causing overheating of the contact components and damaging the equipment. A torque that is too high and repeated tightening can lead to the connection components breaking.

■ Input PV side

Wiring must be performed with the system powered off. Ensure there is no hazardous voltage at any port of the system during wiring. Cables should be labeled, and after wiring, the layout should be clearly visible.



- The MPPT modules for PV input must have their photovoltaic cables and MC4 connectors installed by the customer before initial use.



- Before making MC4 quick plug connector wiring, disconnect the connector wire from the photovoltaic panel to the MPPT module.

Before connecting the shipped quick-plug terminals to the cable ends, ensure that the interconnection cable between the PV module terminals and the

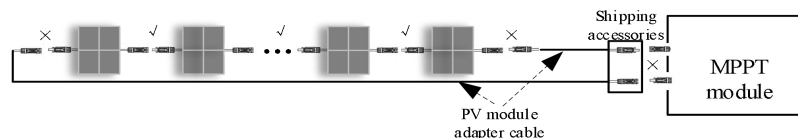

- 1) The PV module comes with standard-length positive and negative output quick-plug cables.
- 2) The interconnection cable is configured due to the transmission distance between the PV module and MPPT.

MPPT module is in a disconnected state.

3) The interconnection cable at the PV module end needs to use MC4 from the PV manufacturer, and the interconnection cable at the MPPT end should use the MC4 from our shipment accessories.

4) The customer must disconnect the interconnection cable between the PV module and MPPT module during initial on-site processing of the interconnection cable and during subsequent maintenance of MPPT products by the company. The disconnection point is shown as "x" in the figure above. Operations should not be performed while powered on.

MC4 terminal wiring description

1) Match the male and female shell and terminal core of the terminal:

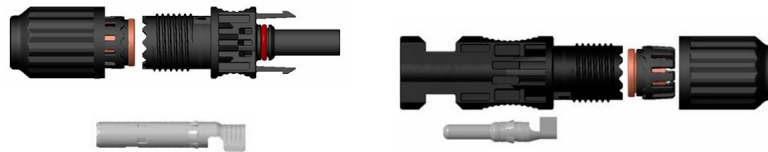

2) PV interconnection cables: Strip the wire length L to 7~8mm, and ensure no more than 3 broken strands:



3) Insert the stripped wire core into the terminal hole, ensuring all the wire cores are inside the terminal hole:



4) The cable insulation layer should contact the crimp core, and use crimping pliers to tightly press the wire core and terminal core.



5) Insert the crimped female and male terminals through end cap 1, end cap 2, and the sealing ring as shown in the diagram, and insert them into the pre-assembled plug (positive) & socket (negative) terminal block until they engage. When it clicks into place, you will hear a "click" sound, and the terminal cannot be pulled out once inserted.



6) After the MC4 terminal of the interconnection cable is installed, it can be connected to the MPPT module MC4 terminal.



 **Danger**

- Before the first use of the MPPT module, and during subsequent maintenance, it is essential to follow the wiring and power-off instructions strictly, otherwise, there is a risk of electric shock.
- Do not disconnect the connector wires while the MPPT is running. Ensure the MPPT is stopped, and the isolation switch on the MPPT module is in the open position.
- The MC4 connectors used to connect with our MPPT must be the ones provided in the product's shipping accessories. Customers are prohibited from using other MC4 connectors, as this may cause damage to the equipment.
- The photovoltaic cables connected to our MC4 should be tinned cables.
- It is strictly prohibited for MC4 connectors to come into contact with corrosive substances.
- The positive and negative terminals of the MPPT input must not be reversed. Before wiring, please measure with a multimeter.

 **Warning**

- The MC4 connectors used to connect with our MPPT must be the ones provided in the product's shipping accessories. Customers are prohibited from using other MC4 connectors, as this may cause damage to the equipment.
- The photovoltaic cables connected to our MC4 should be tinned cables.
- The connector protection level is IP68, but it is strictly prohibited to use it underwater for extended periods.
- It is strictly prohibited for MC4 connectors to come into contact with corrosive substances.

5.8 Grounding Connection

The internal equipment is grounded through the internal frame and cabinet body, with a grounding copper bar inside the cabinet.



- The neutral point of the AC port inside the cabinet is not connected to the cabinet shell.
 - The cabinet should be reliably grounded, with a grounding impedance of less than 4Ω .
-

Cross-sectional area (mm ²) of DC output wire	Minimum cross-sectional area (mm ²) of external protection grounding conductor
$S \leq 16$	S
$16 < S \leq 35$	16
$35 < S$	S/2

Note: The values in this table are valid only if the external protection grounding conductor is made of the same metal as the DC output wire. If this is not the case, the cross-sectional area of the external protection grounding conductor should be determined to produce the same electrical conductivity as the result in this table.

5.9 Signal Connection

In addition to power cables, the MPPT cabinet also has some external communication signals that can be connected as needed.

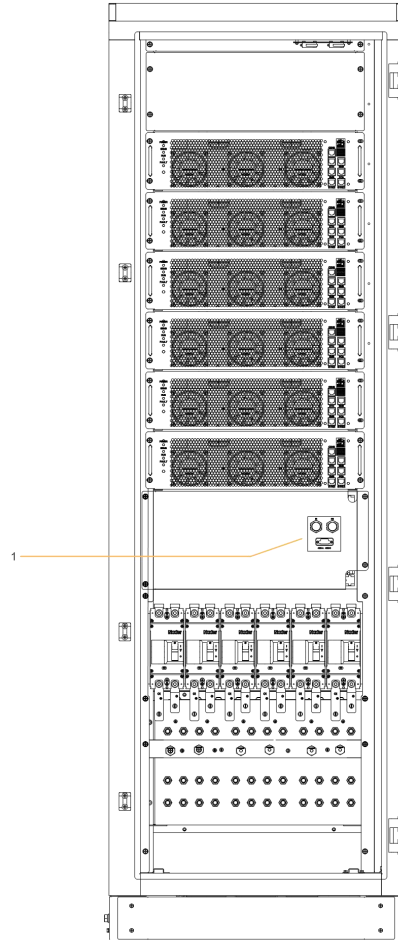





Figure 5-5 External signal interfaces of the MPPT cabinet

The signal interfaces of the MPPT cabinet are defined in the table below.

Table 5-3 External signal interface definition of the MPPT cabinet

			
Position No.	No.	Definition	Description
XT1	1	485A	MPPT cabinet and EMS RS485 communication interface
	2	485B	
	3	NC	

			
Position No.	No.	Definition	Description
P1	1	RS485	MPPT cabinet parallel communication interface
			
Position No.	No.	Definition	Description
P2	1	RS485	MPPT cabinet parallel communication interface

5.10 Pre-operation Inspection

Before starting the Neptune series microgrid MPPT cabinet, after installation, please perform the following checks:

No.	Check item
1	Check if the cables are correctly connected and if the connection points are secure.
2	Check if any installation tools or debris are left inside the cabinet.
3	Check if the DC side voltage is within the allowable range specified in the manual.
4	Check the temperature, humidity, and ventilation conditions around the cabinet.
5	Check if the DC side voltage matches the cable specifications and that the polarity is correct.
6	Check if the cable markings are correct and clearly visible.
7	Check if the safety labels are unobstructed or damaged.
8	Check if the cabinet is deformed or at risk of water ingress.

6. System Maintenance

Due to the influence of environmental temperature, humidity, dust, and vibration, the internal components of the equipment may age, leading to potential failures or reduced service life. Therefore, it is necessary to carry out daily and periodic maintenance, especially in high-temperature environments, frequent starts and stops, with AC power and load fluctuations, strong vibrations or impacts, or corrosive environments with dust/metal dust/hydrochloric acid. In such cases, the interval for regular inspections should be shortened.

■ Regular inspection items:

The following table lists the regular inspection items for this product. It is generally recommended to perform a regular inspection every 6 months. During actual maintenance, please determine the actual inspection cycle based on the product's usage and working environment. Regular maintenance helps prevent product function deterioration and equipment damage.

No.	Check item
1	Check if the surface of the entire machine has debris, dirt, or dust accumulation.
2	Check if the power cable connections are loose, discolored, or if the cable insulation is aging or cracked.
3	Check the external indicators.
4	Check the module fan.
5	Check if the safety labels are unobstructed or damaged.
6	Check if the dust filter is blocked, and if the fan is abnormal. If there is severe dust accumulation, replace the dust filter.
7	Check if there is condensation inside the equipment. If there is condensation, ventilate first.
8	Check the input isolation switch of the MPPT module.
9	Check the DC switch.



- When performing maintenance operations on the equipment, do not operate it while powered on. Disconnect all power sources and leave warning signs to prevent electric shock or equipment damage.
- Maintenance personnel must have professional electrical training and carry qualified maintenance and safety tools.
- The equipment may still be charged after being powered off. Wait for the internal capacitors to discharge completely, and ensure the DC side and MPPT module input isolation switch are fully turned off before operating, ensuring the equipment is in an unpowered state before operation.

7. Disposal

When the equipment can no longer be used and needs to be disposed of, follow the electrical waste disposal regulations of the country/region where the equipment is located. It must not be disposed of as household waste.

8. Appendix

8.1 Technical Data

	Neptune-M120	Neptune-M180	Neptune-M240	Neptune-M300	Neptune-M360
PV Input					
Input voltage range	150-1000V	150-1000V	150-1000V	150-1000V	150-1000V
Input voltage range (DC output and BAT coupling)	150-Vbat,min	150-Vbat,min	150-Vbat,min	150-Vbat,min	150-Vbat,min
Max. Num.of modular	2	3	4	5	6
Max. PV Power	120kW (60kW*2)	180kW (60kW*3)	240kW (60kW*4)	300kW (60kW*5)	360kW (60kW*6)
Num. of MPPT's per modular	4	4	4	4	4
Max. Num. of strings per MPPT	1	1	1	1	1
Rated current per MPPT	45A	45A	45A	45A	45A
Rated power per MPPT	15KW	15KW	15KW	15KW	15KW
DC Output					
Output voltage range	350-1000V	350-1000V	350-1000V	350-1000V	350-1000V
Full load output voltage	600-950V	600-950V	600-950V	600-950V	600-950V
Max. output total current	200A (100A*2)	300A (100A*3)	400A (100A*4)	500A (100A*5)	600A (100A*6)
Num. of DC output	2	3	4	5	6
Rated output total power	120kW (60kW*2)	180kW (60kW*3)	240kW (60kW*4)	300kW (60kW*5)	360kW (60kW*6)
System data					
DC reverse polarity protection	Yes				
DC output fuse protection	Yes				
DC output breaker protection	Yes				
PV input switch	Yes				
Over current protection	Yes				
Over/Under voltage	Yes				

protection	
Insulation monitoring	Yes
Over-heat protection	Yes
IP level	IP54
Max. efficiency	> 99.2%
Cooling method	Intelligent air cooling
Operating temperature range	-40~60°C (45~60°C derating, derating factor 5%/°C)
Storage temperature range	-40~70°C (non-condensing)
Relative humidity	0~95% (non-condensing)
Noise	< 75dB @1m
Maximum operating altitude	4000m (derating above 3000m, derating factor 1%/100m)
PV lightning protection	Tyle II
Communication	Ethernet, RS485
Display	LED
Dimensions (W*D*H)	650*900*2100mm
Weight	280kg 305kg 330kg 355kg 380kg

Certificate

IEC 62109-1, IEC 61000-6-2, IEC 61000-6-4

Expand models

Multiple output channels	Neptune-M120-1	Neptune-M180-1	Neptune-M240-1/2/ 3/4	Neptune-M300-1/2/ 3/4	Neptune-M360-1/2/ 3/4
--------------------------	----------------	----------------	--------------------------	--------------------------	--------------------------

8.2 Quality Assurance Statement

Precautions:

- The product should be protected from dust and moisture to prevent damage or functionality issues.
- Maintenance should be carried out only when the product is fully powered off, discharged, and unpowered.
- After installation, protective measures should be taken to prevent direct contact with live parts.
- The product must be used strictly according to the user manual to avoid abnormal operation.
- After the product is in operation, regular inspections should be performed on the ventilation conditions and dust inside the equipment.
- Avoid using the product in environments with corrosive gases or pollutants.

Liability exemption:

The following conditions are not covered under the quality assurance:

- Damage caused during transportation, handling, or installation due to impact or improper operation.
- Improper installation methods or modifications.
- Exceeding the usage conditions specified in the product manual, such as voltage or current beyond the product specifications, incorrect input power, abnormal external load devices, excessive temperature, or corrosive environments.
- Abnormal equipment caused by disassembly, repair, modification, or research by non-company personnel.
- Damage caused by changing the product's default protection parameters or operating and configuring the product using non-company software.
- Damage caused by abnormal natural environments.

8.3 Contact Information

For any questions during the use of this product, please feel free to contact us.

Please provide the following information to help us assist you better:

- Equipment model
- Equipment SN
- Battery type and photovoltaic module type
- External communication method of the equipment
- Software version number
- Fault code/name
- A brief description of the issue

YUNT website: www.yunt-power.com

Tel: 0755-23592426

Service email: sales@yunt-power.com

Company address: No. 15 Tianbao Road, Shiyan Street, Bao'an District, Shenzhen City, Guangdong Province

YUNT
云天数能