

YUNT

User Manual

STS-1000KS STS Module

V01.00

Contents

1 Product Information	6
1. 1 Model description	6
1. 2 Introduction to STS application system	6
1. 3 STS principles	7
1. 4 Components description	9
1. 5 Product size	10
1. 6 Panel LED indicators	11
1. 7 Technical specifications	12
1. 8 STS and PCS Communication	12
2 Unpacking and Handling	12
2. 1 Unpacking	13
2. 2 Storage precautions	13
2. 3 Handling precautions	13
3 Mechanical Installation	14
3. 1 Installation environment requirements	14
3. 2 Installation space requirements	14
3. 3 Installation tool requirements	16
3. 4 Use of modules in the system cabinet	15
3. 5 Cable preparation	15
3. 6 Installation	16
4 Electrical Installation	16
4. 1 Check before wiring	17
4. 2 Wiring precautions	17
4. 3 Power terminal wiring	17
4. 4 Signal terminal wiring	18
5 Initial Power-On and Operation	20
5. 1 Startup	20
5. 2 Shutdown	21
6 Maintenance and Troubleshooting	21
6. 1 Daily maintenance	21
6. 2 List of faults	21
6. 3 Quality Assurance	22

About the Manual

This manual describes the STS module in terms of its product information, installation, operation and maintenance. More information is available from YUNT's official website or sales channels.

Applicable Scope

This manual is intended for the following devices

STS-1000KS STS modules

Intended readers

- End users
- Installation Engineers
- Maintenance Engineers

Use of the Manual

Please read the manual carefully before using the product and keep it in an easily accessible place.

The content of the manual will be constantly updated and corrected, but there may inevitably be some discrepancies or errors with the actual product. Users should refer to the actual product purchased and can download the latest version of the manual through the official website or sales channels of Yunt Digital Power.

Safety Precautions

Safety declaration

- Please read and follow these safety precautions when installing, operating, or maintaining the product.
- For personal and equipment safety, please follow all safety precautions as marked on the product and described in the manual during installation, operation and maintenance of the product.
- The "Cautions", "Warnings" and "Dangers" in the manual do not cover all safety matters to be observed but are only supplementary to all safety precautions.
- This product should be used in an environment that meets the design specifications, otherwise it may cause malfunctions, and malfunctions or component damage caused by failure to comply with relevant regulations are not within the scope of product warranty.
- We will not bear any legal responsibility for personal safety accidents and property damage caused by the illegal operation of the product.

Definition of security level



Indicates that minor bodily injury or equipment damage may result if instructions are not followed.



Indicates that serious bodily injury or damage to critical equipment may result if instructions are not followed.



Indicates that death or serious bodily injury may result if instructions are not followed.

Setting of safety warning signs

When performing installation, operation, daily maintenance, inspection and other operations on the device, prevent unauthorized personnel from approaching and causing misoperation or accidents. Please comply with the following

- Set up obvious signs at the front and rear switches of the STS module to prevent accidents caused by mistaken closing.
- Warning signs or safety warning tapes should be set up near the operating area.
- After maintenance and inspection, check that the front and rear switches of the device are turned off and the device is powered off.

Safety Precautions

Unpack for acceptance inspection



- Don't install it the product and its accessories are found to have damage, rust, signs of use, etc. when unpacking!

- Don't install it if you find water in the product, missing parts, or damaged parts when unpacking!
- Please check the receipt carefully, and don't install it if you find that the receipt does not match the product name!



- Before unpacking, please check whether the outer packaging of the equipment is intact and whether there is damage, water, moisture, deformation, etc.
- Please check the surface of equipment and accessories for damage, rust, bumps, etc. when unpacking.
- After unpacking, please carefully check the quantity of equipment and accessories, and check whether the information is complete against the receiving list.

Installation and Wiring



- Installation, wiring, maintenance, inspection or component replacement by non-professional personnel is strictly prohibited!
- Before installation and wiring, please disconnect all power to the equipment. Make sure that the front and rear switches of the device are disconnected and de-energized to prevent accidental electric shock.
- Please make sure the equipment is well grounded, otherwise there is a risk of electric shock!



- Be sure to read the product user manual and safety precautions carefully before installation!
- Before carrying out installation work, please make sure that the mechanical strength of the installation location is sufficient to support the weight of the equipment, otherwise, a mechanical hazard may occur!
- It is prohibited to disassemble and assemble the internal structural parts of the device without permission. Prevent the screws from falling accidentally, which may lead to electric shock!
- Please tighten the terminal screws according to the tightening torque specified in the manual. Insufficient or excessive tightening torque may lead to overheating or damage to the connection part and cause a fire hazard.
- After the wiring is completed, please check the wiring to ensure that the input and output, and phase sequence are not wrongly connected and that all wiring is normal!

Power-up and operation



- Before powering up, please make sure the product is well installed and wired firmly, and the external device is allowed to start.
- It is strictly forbidden for non-professionals to operate the product, otherwise there is a risk of injury or death!
- It is forbidden to open the door of the product cabinet or the protective cover of the product, touch any terminals of the product, or disassemble any device or parts of the product under power or running condition, otherwise, there is a risk of electric shock!



- After the wiring operation and parameter setting are completed, please conduct a test run of the machine to confirm that the machine can operate safely, otherwise, it may cause injury to personnel or damage to the equipment.
- Before powering on, please make sure the rated voltage of the product is the same as the power supply voltage. If the power supply voltage is used incorrectly, there is a risk of fire.
- During operation, it is strictly forbidden to touch the equipment shell or fan to prevent unnecessary personal injury.

After power-off



- Turn off the front and rear switches of the equipment promptly and ensure that the power is turned off before inspection.

1 Product Information

1.1 Model description

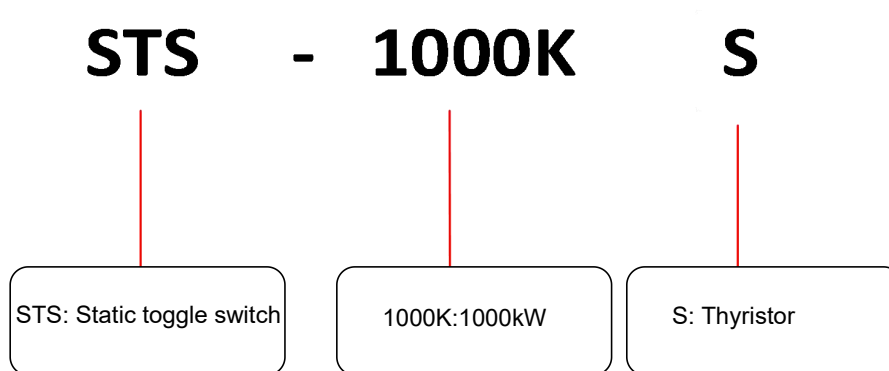

Figure 1 Description of Product Models

1.2 Introduction to STS application system

The STS module is mainly used in conjunction with PCS device to provide a seamless switching function on and off the grid in the system. When the power grid fails, PCS and STS cooperate to switch to the off-grid state to continue supplying power to important loads, thus avoiding losses caused by power outages; when the power grid is restored, PCS and STS cooperate to automatically switch to the grid-connected state. This not only realizes online seamless on-grid transfer to off-grid connection, but also realizes automatic off-grid transfer to on-grid connection, achieving uninterrupted and stable power supply for critical loads.

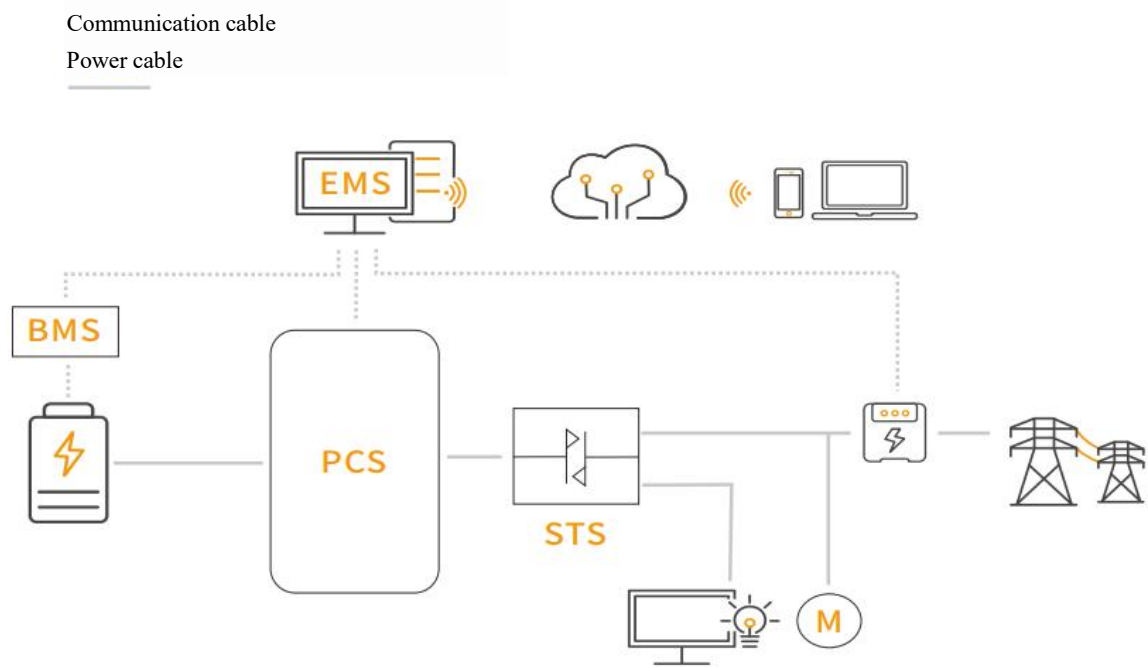

Figure 2 STS application

1.3 STS principles

STS internally adopts active bidirectional thyristor to achieve the function of switching, and the system combination has the following two ways:

(1) PCS+STS

The wiring diagram of PCS+STS application is shown in the following figure, the N line (PN) of PCS and the N line (LN) of the load are directly connected to the N line (GN) of the power grid, and then it is necessary to draw a sampling line from the N line to the N terminal of the STS module.

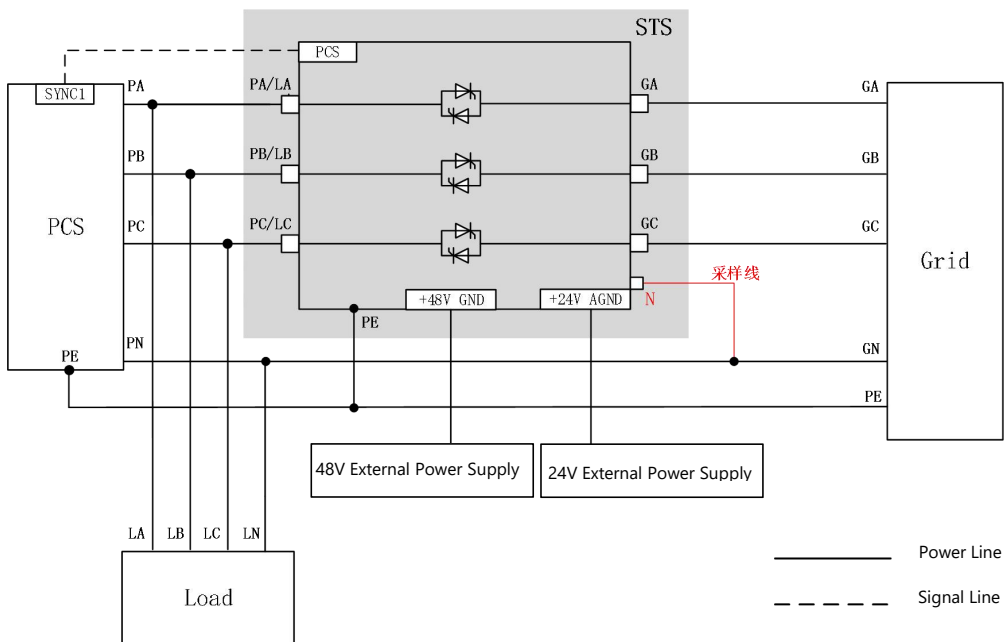

Figure 3 STS application schematic without transformer

(2) PCS+STS+Transformer

In order to improve the stability of the system and the single-phase load capacity of PCS, it is recommended to add an isolation transformer between PCS and STS, the specific wiring is shown in the figure below, at this time, the N line of the transformer's vice-side (TN) and the load's N line (LN) are connected directly to the grid N line (GN), at this time, a sampling line needs to be drawn from the N line to the N terminal of the STS module.

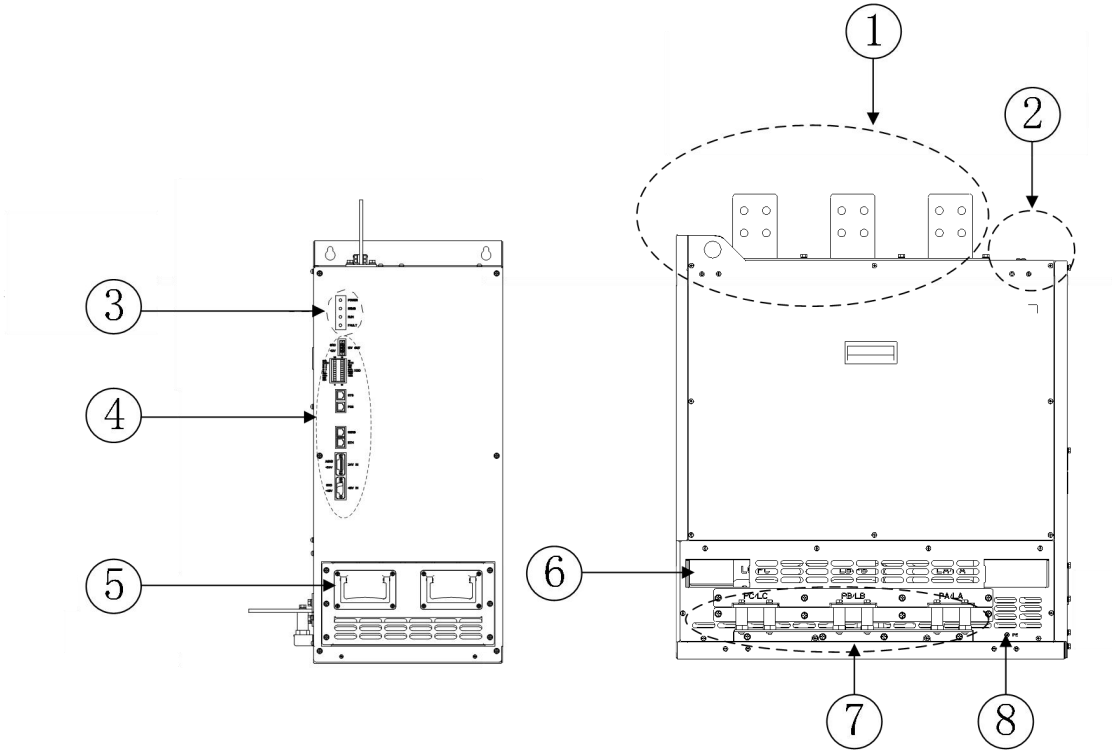
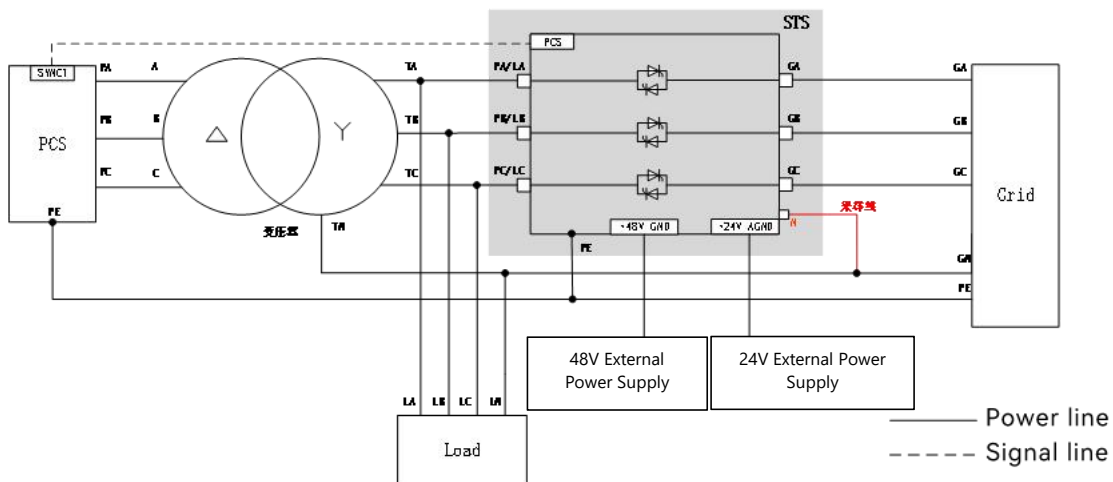

Figure 4 Schematic Diagram of STS Application with Transformer



1.4 Component Description

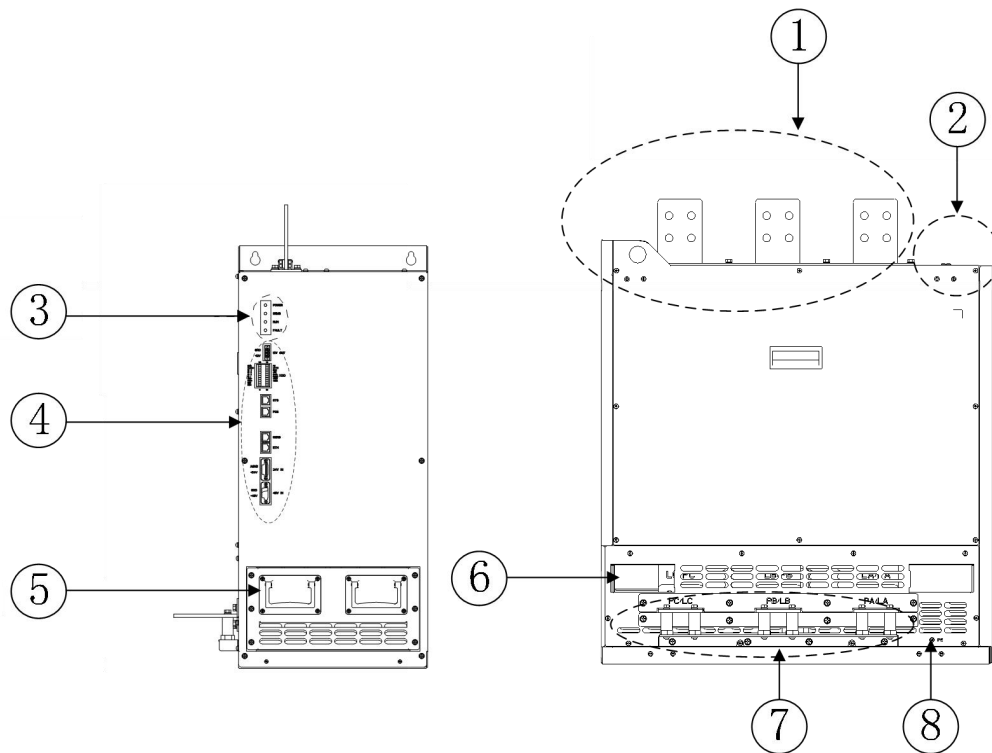

Figure 5 Component Diagram

Table1 Component Description

Serial number	Part No.	Description
1	Grid power terminal	Connection to grid power line
2	Grid N-phase sampling terminal	Connect the grid N-phase sampling line
3	LED Indicator	Operation status indicator
4	24V input power, 48V input power and signal terminals	Connecting 24V power supply, 48V power supply, communication interface and dry node
5	Front handle	For pulling out modules
6	Cut-out window	For lifting the module
7	PCS and load power terminals	Connecting PCS and load power wires
8	PE terminal hole	Connect earth wire

Table 2 Indicator definitions

Indicator	Status	Description
POWER (green)	Always on	PCS port, grid port and external 24V are powered on.
	Fast flash	Software upgrade
	Slow flash	External 24V or PCS port or grid port power up
	Normally off	PCS port and grid port and external 24V not powered up
SEMS (green)	Fast flash	Communication is normal
	Normally off	Communication abnormal
RUN(green)	Always off	STS is in the shutdown state
	Lights up	STS is in grid-connected state
	Fast flash	STS is off-grid
	Slow flash	Grid switch closed
FAULT (red light)	Slow flash	Alarm
	Constant light	Fault, shutdown status

The fast flashing period is 1 second, and the slow flashing period is 3 seconds;

1.7 Technical specifications

Table 3 Technical specifications

Technical specifications	STS-1000KS
Electrical specifications	
Rated grid-side power	1000kW
Rated grid-side current	1443A
PCS access rated power	1000kW
Load access rated power	1000kW
Rated Grid Voltage	400V
Grid voltage range	±15 per cent
Rated grid frequency	50Hz/60Hz
Grid frequency range	±5Hz
Long-term overload capacity	110% (ambient temperature below 40°C)
Transition time from grid to off-grid	< 10ms
Connection Method	3P3W
Maximum efficiency	99.5 per cent

System Parameters	
Topology	Non-isolated
Protection class	IP20
Operating temperature range	-40~60°C (>45°C derating operation, derating factor 5%/°C)
Storage Temperature Range	-40~70°C
Relative Humidity	0~95%, no condensation
Maximum working altitude	4000m (>3000m derating operation, derating factor 1%/100m)
Cooling method	Intelligent air-cooled
Noise (typical)	< 85dB
Human-machine Interaction	LED
Communication Mode	RS485/CAN/EtherNet
Weight	Approx. 110kg
SIZE(W*H*D)	460mm*872mm*700mm
Installation	Modular rack mounting

1.8 Communication between STS and PCS

When the STS module communicates with the PCS module, the following points should be noted for the communication cable between the PCS and the STS:

- The wire of the network cable should be super category 5 or above with shield layer, and the length should not exceed 5m as far as possible.
- If the communication distance is long, in order to improve the stability of the system, you can choose our optical fibre conversion module for communication.

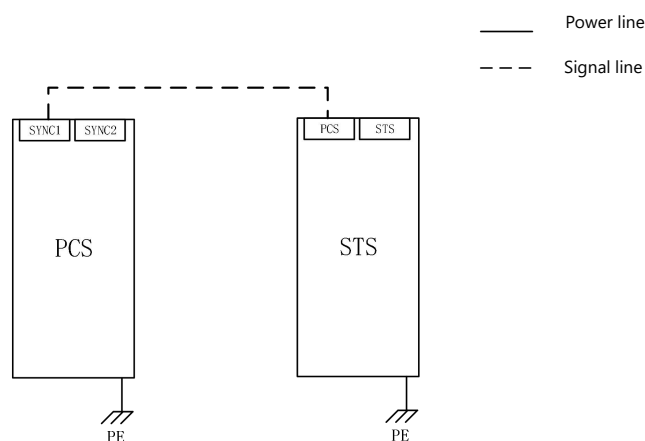

Figure 8 STS and PCS communication diagram

2 Unpacking and Handling

2.1 Unpacking

2.1.1 Precautions for unpacking



Attention

- It is not allowed to remove the package when the equipment is stored, and it will be removed when it is installed.
- When receiving the goods from the transport company, be sure to check the product carefully and meticulously.
- Check each item received against the delivery note. If the goods are missing or damaged, notify the transport company as soon as it is discovered.

2.1.2 Unpacking Steps

Unpacking steps:

1. Remove all ties and open the wooden box.
2. Remove all filling materials.
3. Take out the modules, remove the packaging film and take out the accessories.
4. Observe and ensure that there are no signs of damage.
Dispose of or recycle packaging according to local regulations.

2.1.3 Inspection after unpacking

The following items must be inspected after unpacking:

Table 4 Unpacking Inspection Items

Serial number	Inspection Items	Completion
1	No damage, scratches, dents, etc. in appearance.	<input type="checkbox"/>
2	The objects ordered for the product are complete.	<input type="checkbox"/>
3	The nameplate information is consistent with the ordered product model.	<input type="checkbox"/>
4	Warning labels are not damaged, scratched, blurred, etc.	<input type="checkbox"/>
5	Shipping accessories include: 1) Live mineral desiccant - 5g pack; 2) Product user manual; 3) Warranty voucher label; 4) Common ground shorting cable-60mm;	<input type="checkbox"/>

2.2 Storage Precautions

The device must be placed in a ventilated, clean and dry space, the temperature should be maintained between -40°C~+70°C, the ambient temperature change <1°C / min. For long-term storage, it must be covered or take appropriate measures to ensure that the module is not subject to contamination and environmental impact. After purchasing the module, users must pay attention to the following points for temporary storage and long-term storage:



- When storing the module, try to put it into our packing box according to the original packing.
- Do not allow the device to be placed in humidity, high temperature or outdoor exposure for a long time.

2.3 Handling Precautions



- At least 4 persons are required to carry the equipment to the proper position or use a forklift truck.
During the handling process, the equipment should be lifted as low as possible.
- It is forbidden to have a big shake, and should try to ensure that the handling process of the equipment is as smooth as possible.
- Lifting and lowering should be carried out gently, avoiding shocks or vibrations. Be careful not to press the feet.

When moving, take care that the ground is level and there are no sharp objects in contact with the ground.

3 Mechanical installation

3.1 Installation Environment Requirements

Table 5 Installation environment requirements

Item	Environmental requirements
Installation Site Requirements	This product is for in-cabinet installation and needs to be installed in the final system.
Contamination Level	2

3.2 Installation Space Requirements

(1) If there is a baffle around the installation position of STS module, the baffle should be opened to avoid the opening, so that the module power copper row can pass through the baffle of the system cabinet, as shown in the following figure.

(2) The cabinet should reserve space for power cable routing and ventilation, and it is recommended to use copper rows to connect STS.

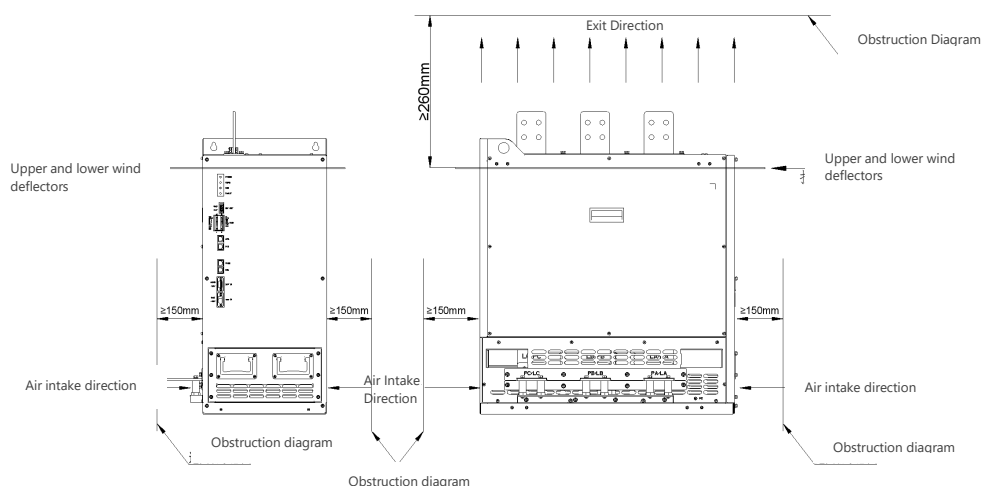

Figure 9 Installation Space Requirements Schematic

3.3 Use of modules in the system cabinet

3.3.1 Heat Dissipation Requirements

(1) Calculation of system airflow, there are two ways to calculate system airflow.

Method 1: Calculation according to the total system loss

Calculated in accordance with the thermal formula, according to the formula: $V = Q / (CP * \rho * \Delta T)$, CP for the current temperature of the specific heat of air (kJ / (kg * K)), ρ for the current temperature of the air density (kg / m³), the current temperature is the average temperature of the inlet and outlet wind, ΔT the temperature difference between the system inlet and outlet (outdoor cabinets are generally selected from the 18°C), Q for the system's total loss (kW) (strong sunshine area of Q value), thus the system air volume calculation. (also need to add solar radiation), the formula can be calculated from the system air volume V (m³ / s).

Method 2: According to the module air volume calculation

The air volume v of a single STS module of Yunt is as follows:

STS-1000KS module maximum air volume 1392CFM (0.654m³/s), then the system air volume $V = n * v$, n is the number of system modules, v individual module air volume.

(2) System fan selection

System fan selection is based on the system air volume V decision, its parameters are mainly the fan's maximum air volume and wind pressure, under the premise of fan wind pressure and system impedance matching, the maximum air volume of the system fan is equal to 1.5 to 2 times the system air volume, i.e., (1.5 to 2) * V. If the fan wind pressure is very high and the system impedance is small, then it can be close to 1.5 times; if the fan wind pressure is low and the system impedance is large, then it can be Press 2 times or even greater than 2 times.

3.3.2 Heat Dissipation Recommendations

When STS-1000KS module is used in the energy storage cabinet system, the temperature difference ΔT between the air inlet and outlet of the module (including the air inlet and outlet of the cabinet) is recommended to be no more than 20°C, and the specific test points are shown in the following figure:

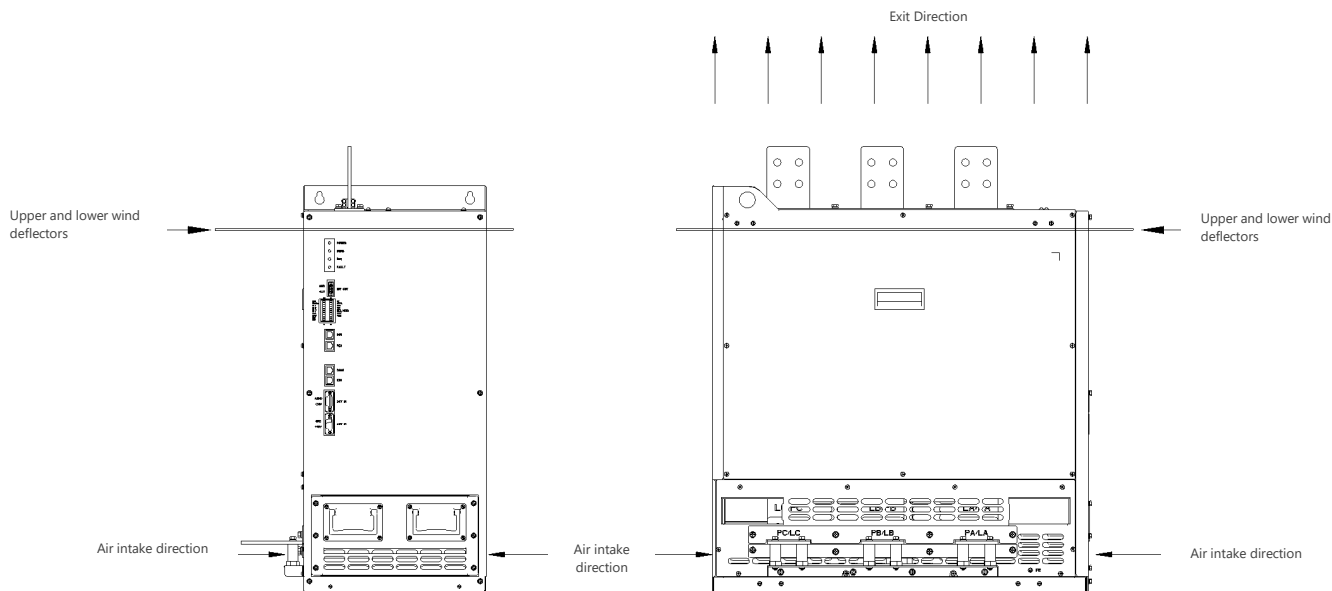

Figure 10 Schematic diagram of the module in the system cabinet

3.4 Cable Preparation

Table 6 Cable Size Recommendations

Cable Wiring Location	Maximum Voltage/Current	Terminal Specification	Cable Recommendation (min.) (copper core)
GA, GB, GC	400V/1520A	SC terminal M10	150mm ² * 5
N (Sampling line)	400V/18A	RVS terminal M8	0.83mm ²
pa/la, pb/lb, pc/lc	400V/1520A	SC terminal M10	150mm ² * 5
PE	-	SC terminal M8	150mm ² * 2
20PIN signal terminal	12V/1A	Socket Shrapnel Crimp Terminal	0.5~1mm ²
+12V Output Terminal	12V/2W	SVS1.25-3.5	0.21 mm ²
+24V Input Terminal	24V/15W	SVS1.25-3.5	0.21 mm ²
+48V input terminal	48V/480W	SVS1.25-3.5	0.83mm ²
SYNC1/SYNC2/ETH/CONS	-	Ethernet Connectors	Ultra Category 5 cable

3.5 Installation

The installation procedure for the device is as follows:

- (1) At least 4 installers are required for safety. Grab the handles on the side of the equipment with one hand and hold the equipment from underneath with the other hand to insert it into the corresponding position in the cabinet or use a lift truck directly;
- (2) Slowly push the device completely into the slot;
- (3) Tighten the front 2 fixing screws, the side 8 fixing screws and the rear 2 fixing screws on the panel of the device to secure it to the cabinet with a mounting torque of 6 N·m;
- (4) Follow the sequence from left to right or top to bottom to install the device into the cabinet sequentially.

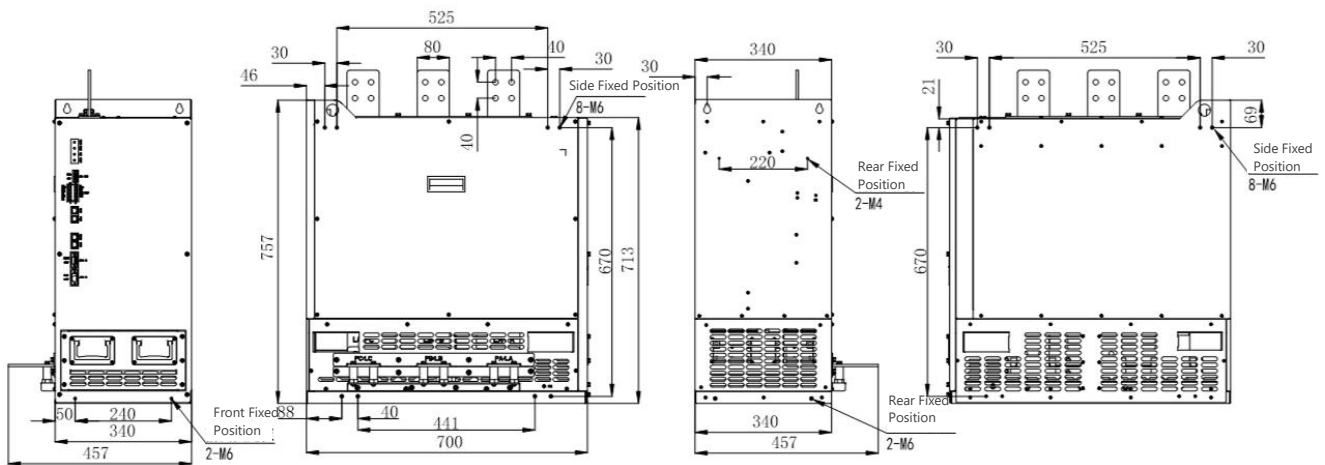

Figure 11 Installation Schematic

4 Electrical Installation

4.1 Check before wiring

In order to ensure the life safety of personnel, the necessary safety precautions must be taken when performing electrical installation of this product. The following procedures must be followed when performing electrical

installation:

- All power sources connected to the equipment must be disconnected to ensure that the equipment is in a non-powered state.
- Warning signs must be left at the disconnected locations to prevent them from being re-energised during installation.
- The installation of the equipment must be carried out only by specialised personnel and in strict accordance with the instructions in the user manual.
- The installer must comply with the relevant electrical operating regulations of the country or region in which he/she is working.
- Necessary grounding connections must be made.

4.2 Wiring Precautions



Before installation, the device must be disconnected from all switches of the external preamplifier to ensure that all external cables and the device internal are in a non-electrical state.

Installation with electricity is prohibited.

4.3 Power Terminal Wiring

The power terminals of the STS module are on the top and side of the module and contain the grid side terminals, PCS/load side terminals, and ground terminals, as shown in the figure below. The function definition of each terminal is shown in the following table.

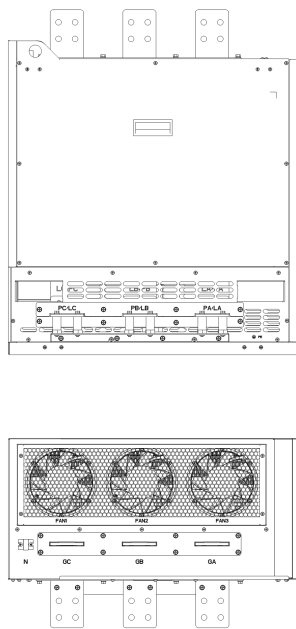

Figure 12 Schematic diagram of power terminals

Table7 Power Terminal Definitions

Part	Name	Description
Grid side	GA	Grid phase A
	GB	Grid phase B
	GC	Grid phase C
	N	Grid N-phase sampling terminal wiring
PCS/load side	PA/LA	PCS and load phase A
	PB/LB	PCS and load B phase
	PC/LC	PCS and load phase C
Ground	PE	Earth ground (reliable grounding required)

4.4 Signal Terminal Wiring

The signal terminals of the STS module are on the front of the module, including power terminals, communication terminals and DIO terminals, as shown in the figure below, and the function definition of each terminal is shown in the table below.

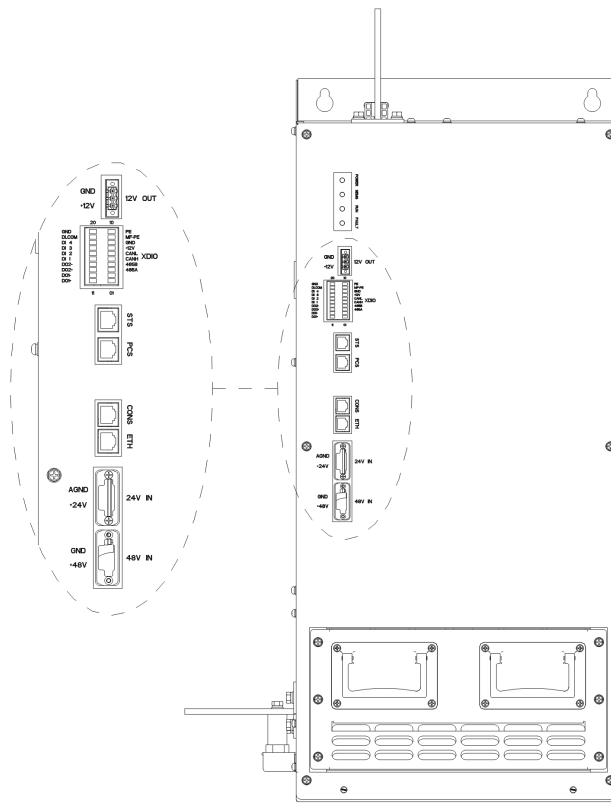

Figure 13 Schematic diagram of signal terminals

Table 8 12V DC power supply terminal definition

+12V OUT			
PIN	Signal Name	Purpose	Remarks
1	+12V	STS internal+ 12V DC output for external fibre optic communication module power supply, power consumption 2W.	
2	Empty		
3	GND		

Table 9 24V DC power supply terminal definitions

+24V IN			
PIN	Signal Name	Purpose	Remarks
1	+24V	External +24V DC input (must be connected) to establish communication connection with PCS.	Power supply 24V± 15%/15W
2	Empty		
3	AGND		

Table 10 48V DC Power Supply Terminal Definitions

+48V IN			
PIN	Signal Name	Purpose	Remarks
1	+ 48V	External +48V DC input (must be connected) to ensure normal operation of the cooling fan.	Power supply power 48V± 15%/480W
2	Empty		
3	GND		

Table11 RJ45 Signal Terminal Definitions

Interface	Function	Description
PCS	Communication interface for STS and PCS	
STS	STS and STS communication interface	
ETH	Reserved Ethernet communication	
CONS	Debugging interface	Connecting the Intelligent Assistant

Table 12 20PIN signal terminal definitions

XDIO			
PIN	Signal Name	Purpose	Remarks
1	Empty		
2	Empty		
3	485A2	Reserved 485 communication interface 2	
4	485B2		
5	CANH	Reserved CAN communication interface	
6	CANL		
7	+12V	+ 12V output power supply	Total power supply output 6W
8	GND		
9	MF-PE		If a fibre optic module is used for PCS and STS communication, remove the short wires on pins 1 and 2 and use them to short pins 9 and 10.
10	PE		
11	DO1+	Reserved DO	Relay dry contact output Support 12V/0.3A
12	DO1-		
13	DO2+		
14	DO2-		
15	DI1	Reserved DI	Support 12V/0.3A input
16	DI2		
17	DI3		
18	DI4		
19	DI_COM	DI Common Ground	
20	GND	+ 12V output power supply ground	

DI signal connection method can support both external power supply and internal power supply, the connection method reference is shown below.

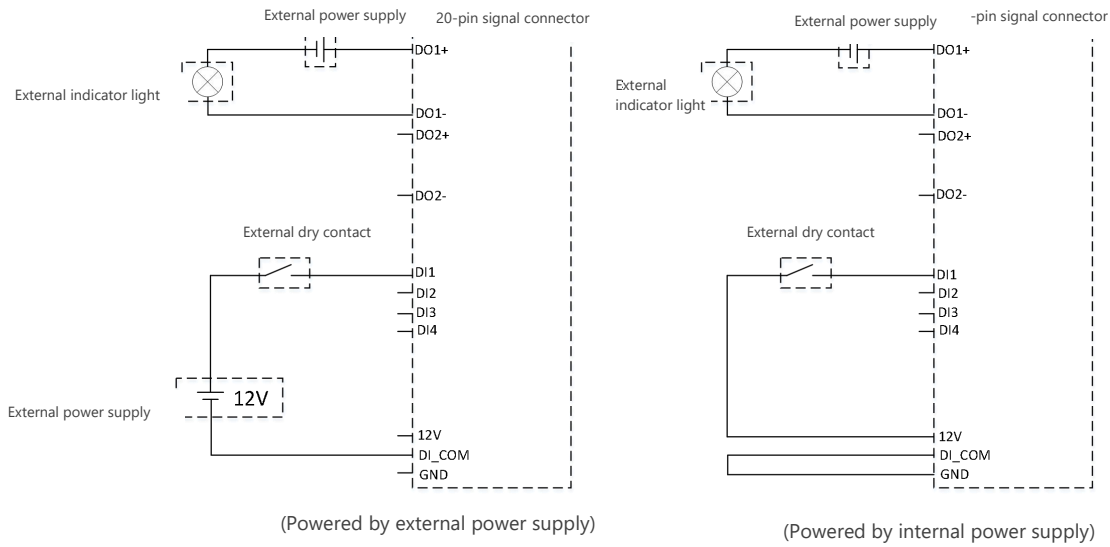

Figure 14 DI, DO wiring diagram

5 Initial Power-On and Operation

5.1 Startup

Before power-on, check whether the external three-phase power supply is normal or not, after confirming that it is correct, operate according to the following steps:

- (1) Disconnect the three-phase power supply of STS module.
- (2) Check the three-phase power wiring, signal wiring and communication wiring of STS module.
- (3) Turn on the three-phase power supply of STS module, external 24V power supply and external 48V power supply.
- (4) STS module is faultless, through the EMS to the PCS issued "power on" command.

Instruction:

The STS module should be powered on strictly according to the above steps, otherwise it may damage the STS module or make it work abnormally.

STS module defaults to shutdown state after power on, the internal thyristor is disconnected.

5.2 Shutdown

STS module normal shutdown operation steps are as follows:

- (1) Send "shutdown" command to PCS through EMS.
- (2) The internal thyristor of the STS module remains in the previous state.
- (3) Run the fan continuously for 5 minutes to cool down the STS module.
- (4) Disconnect the STS module external power switch.

Instructions:

Set a warning sign at the disconnect switch to prevent others from powering up the module by mistake.

6 Maintenance & Troubleshooting

6.1 Routine Maintenance

For each on-site maintenance, a functional check of the STS module should be carried out, which mainly includes:

- (1) Checking the connection cables;
- (2) Checking the working condition of the STS module;
- (3) Check the operation mode switching of the STS module;
- (4) Check the indicator display status of STS module;

6.2 Fault List

STS-1000KS static diverter switch has a perfect fault protection function, once a fault occurs, it will stop automatically, and users can read the relevant fault information through EMS.

Users can carry out preliminary self-test on the generated faults through the prompt information in the following table, observe the fault phenomena, analyse the causes and try to solve them. Attention, please do not open the cover of STS module when self-testing the fault. If the problem cannot be solved, please contact the sales channel or YUNT.

The fault reset method is manual reset:

Manual reset faults: after the occurrence of this type of faults, pending the troubleshooting and elimination of the fault conditions, it is necessary to manually reset the PCS through the EMS, so that the STS module can exit the fault state.

Table 13 Fault List

No.	Fault name	Reset mode	Possible cause	Processing method
1	Grid overvoltage	Manual reset	AC side input voltage is too high	Check whether the grid voltage is normal
2	Grid undervoltage	Manual reset	AC side input voltage too low	Check if the grid voltage is normal
3	Grid overfrequency	Manual reset	AC side input voltage frequency too high	Check whether the grid voltage is normal
4	Grid underfrequency	Manual reset	AC side input voltage frequency too low	Check whether the grid voltage is normal
5	Grid phase sequence error	Manual reset	AC side input voltage phase sequence error	Adjust the phase sequence of AC side input voltage
6	Grid phase loss	Manual reset	Single-phase input voltage on AC side is too low	Check whether the grid voltage is normal
7	Positive and negative 12V power supply fault	Manual reset	Abnormal power supply of power board	Please contact the manufacturer
8	STS module over temperature	Manual reset	Heat sink temperature too high	Check if the heat sink fan is damaged
9	Fan failure	Manual reset	Damaged cooling fan	Contact factory

6.3 Quality Assurance Notes

Caution:

- The product avoids penetration of dust and moisture to avoid causing damage to the product or affecting its function.
- Product maintenance needs to be carried out in the case of complete power failure, discharge, and no electricity to carry out maintenance work.
- The product should be installed to do a good job of charged parts protection, to prevent people from directly touching.
- The use of the product should be in strict accordance with the product instruction manual within the scope of the positive production operating parameters, so as not to cause equipment abnormalities.
- After being put into operation, the ventilation conditions of the product should be checked regularly, and the dust in the operating environment of the product should be cleaned up.
- The product should be avoided to work in the environment with corrosive gases or pollutants.

Liability exemption:

- When the following conditions occur, when the quality assurance is not carried out.
- Damage caused by impact or abnormal operation during transport, handling, or installation.

Incorrect installation or modification.

- Exceeding the operating conditions specified in the product's instruction manual, such as voltage or current exceeding the product's specifications, incorrect input source, abnormal external load equipment, high or low temperature, highly corrosive environments, etc.
- Abnormalities caused by disassembling, repairing, altering, researching, etc., not by our service personnel.
- Damage caused by changing the default protection parameters of the product, or operating and configuring with software products other than those of the Company.
- Damage caused by abnormal natural environment.

YUNT

Shenzhen Yunt Digital Power Co., Ltd.

Tel: 0755-23592426

Email: sales@yunt-power.com

Website: www.yuntpower.com

Address: Building 1, No.15, Tianbao Road, Shiyan Street, Baoan District, Shenzhen, Guangdong, China