



User Manual
STS-120/200/250 STS Module

V01.02

Catalogue

1 Product information	6
1.1 Product model description	6
1.2 System application introduction	6
1.3 System wiring	7
1.4 Part description	8
1.5 Product dimensions	9
1.6 Indicator	9
1.7 Technical specification	10
1.8 Parallel application	11
1.9 Application with isolation transformer	12
2 Unpacking and handling	13
2.1 Unpacking	13
2.2 Precautions for storage	14
2.3 Precautions for handling	14
3 Mechanical installation	14
3.1 Installation environment requirements	14
3.2 Installation space requirement	15
3.3 Use of the module int the system cabinet	15
3.4 Cable preparation	17
3.5 Installation	18
4 Electrical installation	18
4.1 Pre-wiring inspection	18
4.2 Precautions of wiring	19
4.3 Power terminal connection	19
4.4 Signal terminal connection	20
5 Initial Power-Up and Operational Startup	22
5.1 Power-On Operation Guide	22
5.2 Power-Off Operation Guide	22
6 Maintenance and Servicing	23
6.1 Routine maintenance	23
6.2 Fault list	23
6.3 Quality Assurance	25

About this manual

This manual mainly introduces the product information, installation, operation and maintenance instructions of the STS module. More information can be obtained from the official website of the company or the sales channel.

Scope of application

This manual is applicable to the following devices

- STS-120、STS-200、STS-250 STS Module

Target audience

- End Users
- Installation engineers
- Maintenance engineers

Use of manual

Please read the manual carefully before using the product and keep the manual in a convenient place.

The content of the manual will be updated and amended continuously, but it is inevitable that there will be a slight discrepancy or error with the actual material. Users please refer to the actual products purchased, and can download the latest version of the manual through the official website or sales channels.

Safety precautions

- Please read and follow the safety precautions before installing, operating, and maintaining the product.
- For the safety of persons and equipment, please follow all safety precautions indicated on the product and in the manual during installation, operation, and maintenance.
- The "Caution", "Warning", and "Danger" items in the manual are not representative of all safety precautions that should be followed, but are supplementary to all safety precautions.
- This product should be used in an environment that meets the design specifications, otherwise it may malfunction. Damage caused by failure to comply with relevant regulations, such as abnormal function or damage to components, is not covered by the product quality guarantee.
- The company will not assume any legal responsibility for personal safety accidents or property losses caused by improper operation of the product.

Definition of Security Level



It states that improper operation may result in minor bodily injury or equipment damage.



It states that improper operation may result in serious bodily injury or damage to vital equipment.



It states that improper operation may result in death or serious bodily injury.

Setting of safety warning signs

During the installation, operation, daily maintenance, overhaul and other operations of the equipment, in order to prevent the proximity of irrelevant personnel and misoperation or accidents. Please comply with the following:

- Clearly mark the front and rear switches of the STS module to prevent accidents caused by false closing.
- Put up warning signs or safety warning belts near the operation area.
- After performing maintenance and overhaul operations, ensure that the front and rear switches of the device are off and no power is available.

Safety precautions

Unpacking and acceptance



- Do not install if the product or accessories are found to be damaged, corroded, or used.
- Do not install if water is found inside the product, parts are missing, or parts are damaged during unpacking.

- Please carefully check the receipt of goods, found that the receipt of goods does not match the product name, do not install!



- Before unpacking the equipment, check whether the outer package is intact,damaged,damp,or deformed.
- Before unpacking, check the surface of the equipment and accessories for damage, rust, or bruises.
- After unpacking, please check the receiving list carefully to check whether the quantity and information of equipment and accessories are complete.

Installation and wiring



- Non-professional personnel are strictly prohibited from installing, wiring, maintaining, inspecting or replacing the equipment.
- Before connecting cables, power off all devices. Ensure that the front and back of the equipment is disconnected without power, to prevent accidental electric shock!
- Ensure that the device is properly grounded; otherwise, electric shock may occur!



- Please read the user manual and safety precautions carefully before installation!
- Before installing the device, ensure that the mechanical strength of the installation position is sufficient to support the weight of the device. Otherwise, mechanical hazards may occur.
- It is strictly prohibited to disassemble and assemble the internal structural parts of the equipment! Prevent accidental drop of screws and electric shock hazard!
- Tighten the terminal screws according to the tightening torque specified in the manual. An insufficient or excessive tightening torque may cause overheating or damage to the connection, which may result in fire hazard.
- After the wiring is complete, check the wiring to ensure that the input and output, phase sequence are not wrong, and all the wiring is normal!

Power on and run



- Before powering on the device, ensure that the product is properly installed, cables are securely connected, and external devices are allowed to start.
- Non-professional personnel are strictly forbidden to operate the product, otherwise it may cause injury or death!
- Do not open the door of the cabinet or the protective cover of the product, touch any terminal of the product, or disassemble any device or part of the product when the product is powered on or in operation, otherwise there is a risk of electric shock!



Warning!

- After wiring and parameter setting, run the machine to ensure that it can operate safely; otherwise, personnel may be injured or equipment may be damaged.
- Before powering on, ensure that the rated voltage of the product is consistent with the power supply voltage. If the power supply voltage is used incorrectly, there is a risk of fire.
- Do not touch the device cover or fan during operation to prevent unnecessary personal injury.

After powering off



Danger!

- Turn off the front and back switches of the equipment in time, and ensure that the power is off before checking!

1 Product information

1.1 Product model description

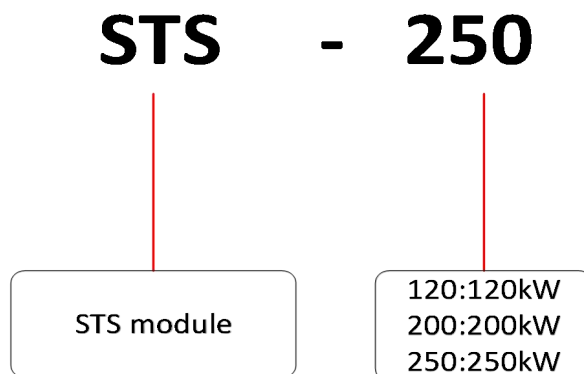

Figure 1 Product model description

1.2 System application introduction

STS module is mainly used with PCS, and acts as a seamless switching function in the system. When the power grid fails, PCS and STS cooperate to switch to the off-grid state to continue supplying power for important loads and avoid losses caused by power outage. When the power grid is restored, PCS and STS

cooperate to automatically switch to the grid-connected state. It can not only realize seamless online grid-connection to off-grid, but also realize automatic off-grid to grid-connection function, so as to achieve uninterrupted and stable power supply of critical loads.

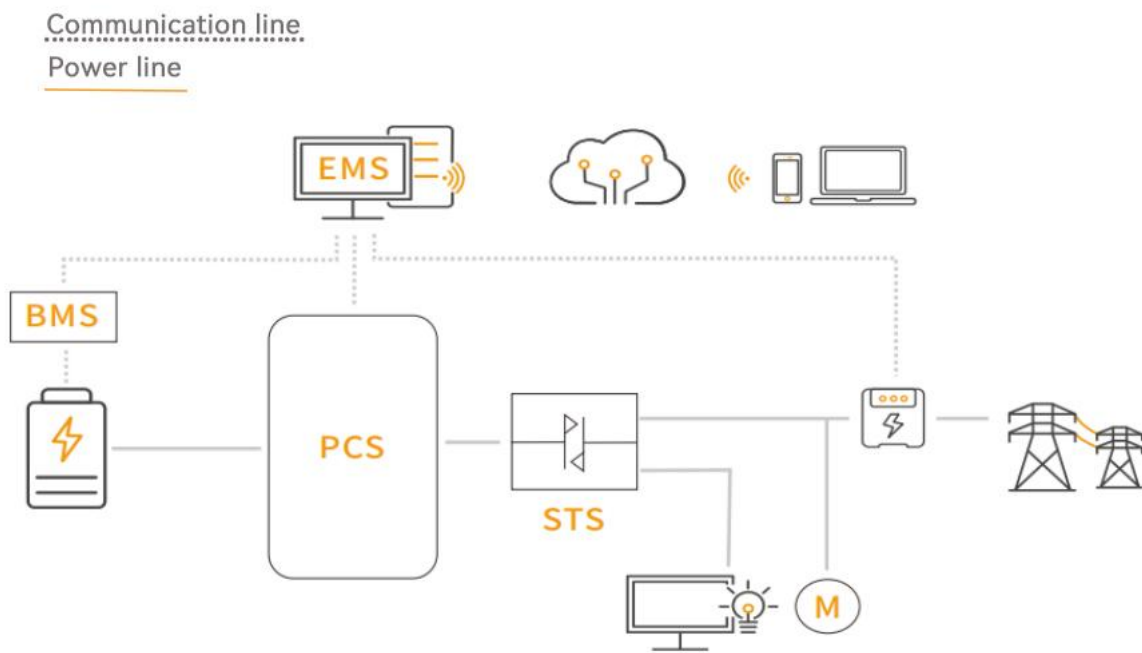

Figure 2 STS Application diagram

1.3 System wiring

STS uses active bidirectional thyristor to realize the function of switching. When wiring the system, pay attention to connecting both the PCS N line and the load N line to the LN terminal of the STS module.

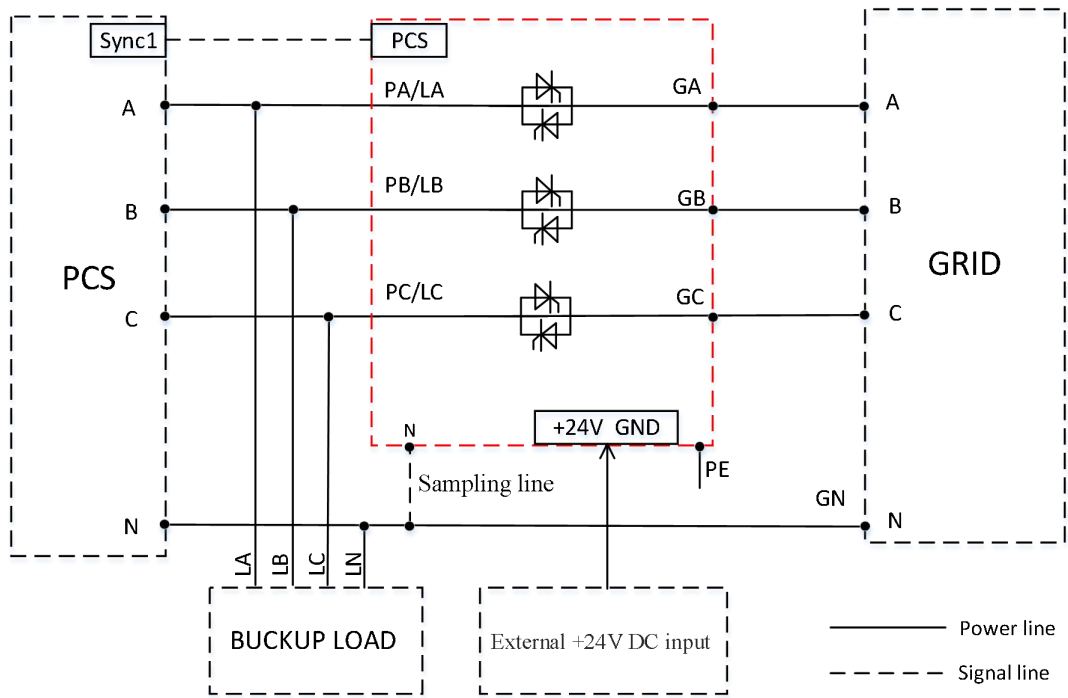

Figure 3 STS Circuit block diagram

1.4 Part description

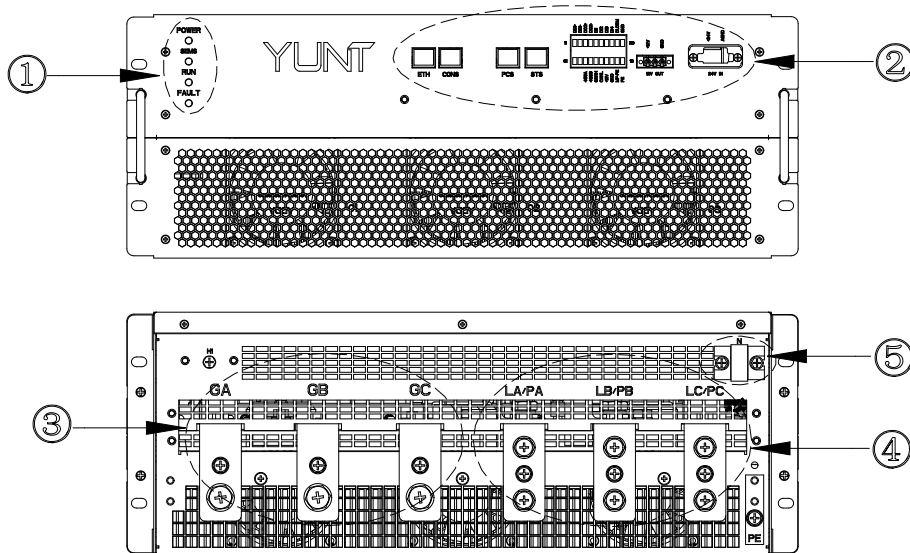

Figure 4 Part diagram

Table 1 Part description

Serial number	Part	Description
1	LED indicator	Running status light

2	24V input power and signal terminals	Connect 24V power supply, parallel interface, and DIO signal interface
3	Power grid connection ports	
4	PCS and load connection ports	
5	N-phase sampling terminal	

1.5 Product dimensions

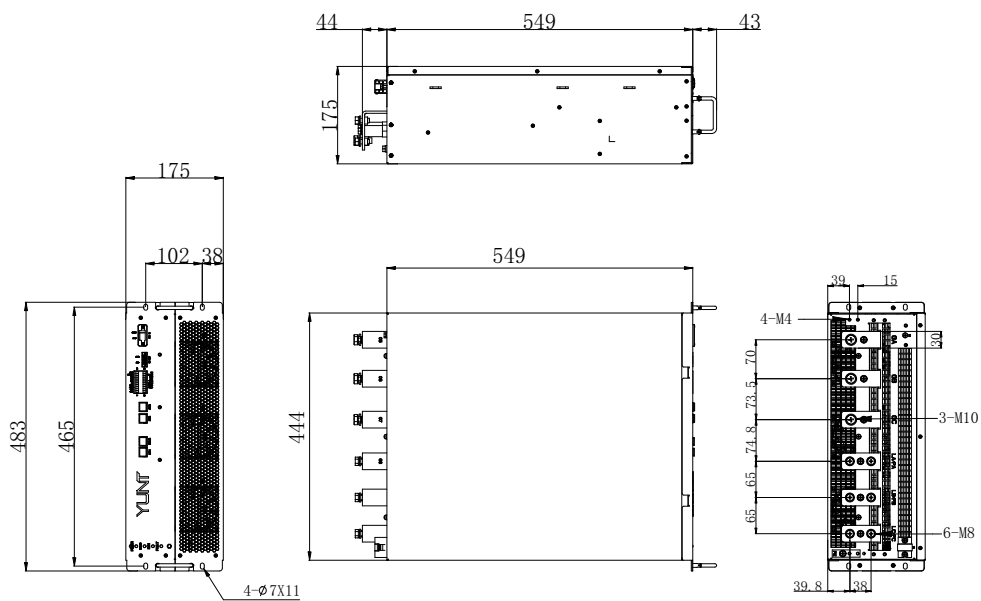

Figure 5 Dimension picture (Unit:mm)

1.6 Indicator

On the front panel of the STS module, there are indicators related to product operation, as shown in the following figure, and the specific function definition is shown in the following table.

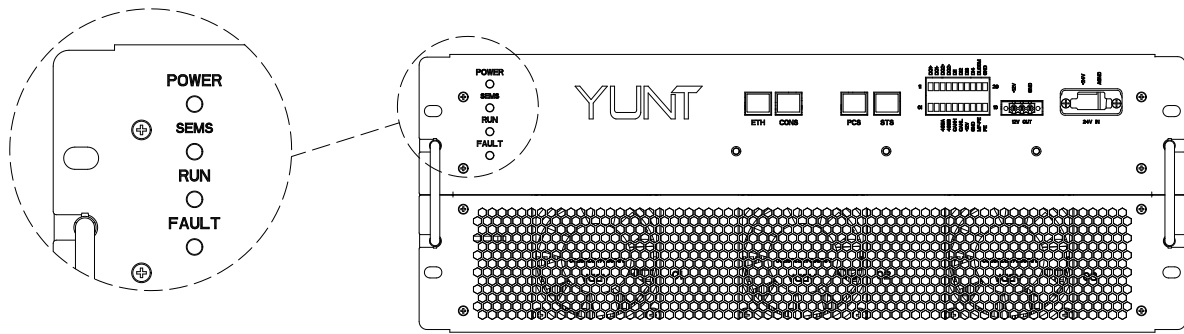

Figure 6 LED indicator of front panel

Table 2 indicator definition

Indicator	State	Description
POWER(green)	Steady on	Power on the PCS port or the grid port
	Quick blinking	Software upgrade
	Slow blinking	Power on the external 24V
	Steady off	PCS ports, power network ports, and external 24V ports are not powered on
SEMS(green)	Quick blinking	Communication Normal
	Steady off	Communication exception
RUN(green)	Steady off	STS is in Shutdown State
	Steady on	STS is in on-grid State
	Quick blinking	STS is in off-grid State
	Slow blinking	Grid-connected switch is closed
FAULT(red)	Slow blinking	Alarm
	Steady on	Fault, shutdown state

The quick blinking cycle is 1 second, and the slow blinking cycle is 3 seconds.

1.7 Technical specification

Table 3 Technical specification

Specifications	STS-120	STS-200	STS-250
Electrical specification			

Rated power(grid)	120kW	200kW	250kW
Rated current(grid)	182A	304A	380A
Rated power(PCS and load)	120kW	200kW	250kW
Rated current(PCS and load)	182A	304A	380A
Rated voltage(grid)	380V/400V		
Voltage range(grid)	±15%		
Rated frequency(grid)	50Hz/60Hz		
Frequency range	±5Hz		
Long-term overload capacity	110% (ambient temperature ≤40 °C)		
Switching time	<10ms		
Connection mode	3P+PE		
Max efficiency	99.5%		
System parameter			
Topological structure	Non-isolated		
Protection level	IP20		
Operation temp range	-40~60°C (>45°C derating work)		
Storage temp range	-40~70°C		
Relative humidity	0~95%,no condensation		
Maximum altitude	4000m (>3000m derating work)		
Cooling mode	Intelligent air cooling		
Noisy (typical value)	<70dB		
HMI	LED		
Communication mode	RS485/CAN/EtherNet/DIO		
Weight	27kg		
Dimensions(W*H*D)	444mm*175mm*549mm		
Installation mode	Rack mount		

1.8 Parallel application

The STS supports parallel operation of two units, achieving a total power capacity of up to 500 kW. For higher power requirements, a 1 MW STS module provided by our company is available as an option:

- STS modules must be installed within the same cabinet for parallel operation.
- Ethernet cables should be made of shielded Cat 5e or higher-grade material.
- The cable length should preferably not exceed 5 meters, and cable routing should avoid introducing external interference signals.
- To achieve good current-sharing performance after paralleling, the power cables of the paralleled units should be as equal in length as possible. For example, for Phase A: P1 = P2, G1 = G2; the same principle applies to the other phases.

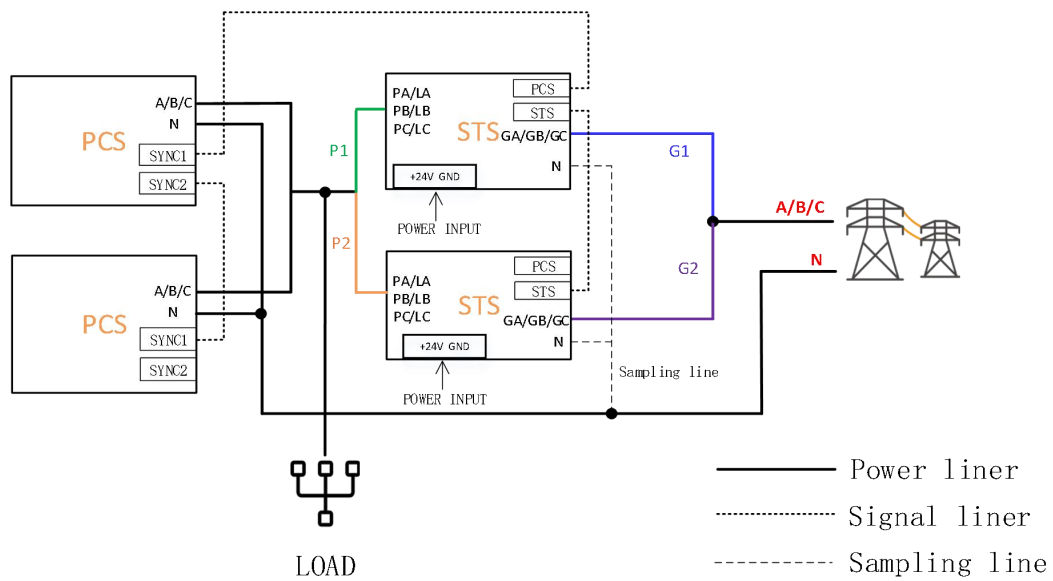

Figure 7 Diagram of multi-unit parallel Application

1.9 Application with isolation transformer

To improve system stability, enhance the single-phase load capability of the PCS, it is recommended to add an isolation transformer between the PCS and STS. The specific wiring is shown in the following figure.

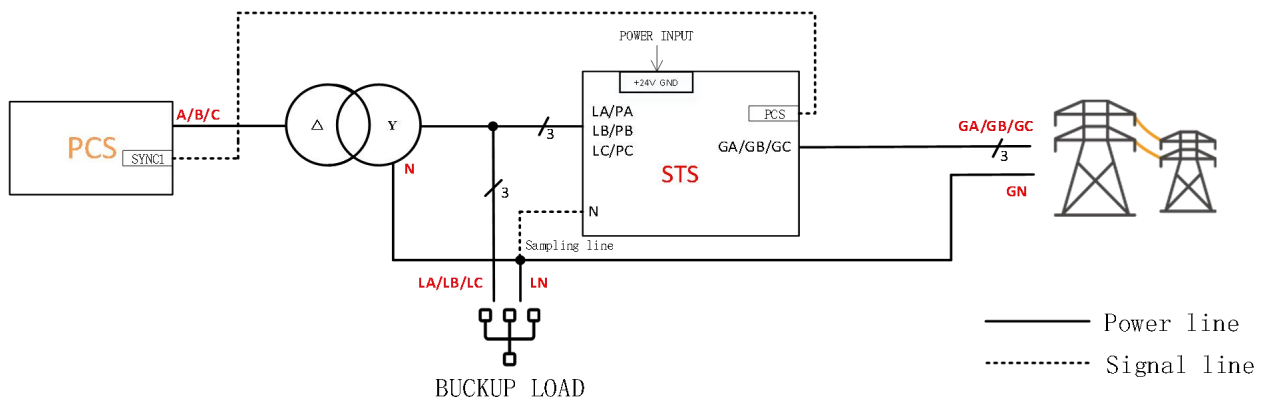

Figure 8 Diagram of multi-unit application

2 Unpacking and handling

2.1 Unpacking

2.1.1 Precautions for unpacking



- Do not remove the packaging of the device during storage. Do not remove the packaging before installation.
- When receiving goods from a shipping company, it is important to carefully inspect the products.
- Check each item received against the supply sheet. If the goods are missing or damaged, the shipping company shall be notified immediately upon discovery.

2.1.2 Unpacking procedure

Unpacking Steps:

- Remove all tie wraps and open the carton.
- Remove all filling materials.
- Take out the module, remove the protective film, and take out the accessories.
- Inspect and ensure there are no signs of damage.
- Dispose of or recycle the packaging in accordance with local regulations.

2.1.3 Checking after unpacking

After unpacking, the following items must be checked:

Table 4 Check items of unpacking

No	Check items	State
1	Appearance no damage, scratches, dents and other phenomena.	<input type="checkbox"/>
2	The items ordered are complete.	<input type="checkbox"/>
3	The nameplate information is consistent with the ordered product model.	<input type="checkbox"/>
4	The warning label is not damaged, scratched or blurred.	<input type="checkbox"/>
5	Shipping accessories include: 1) Live ore desiccant -5 grams; 2) Product user manual; 3) Warranty certificate label;	<input type="checkbox"/>

2.2 Precautions for storage

The device must be placed in a clean and dry space with a temperature ranging from -40°C to $+70^{\circ}\text{C}$, and the ambient temperature change is less than $1^{\circ}\text{C}/\text{min}$. For long-term storage, it is necessary to cover or take appropriate measures to ensure that the module is not affected by pollution and the environment. After the user purchases the module, temporary storage and long-term storage must pay attention to the following points:



- Store in the original packaging as far as possible into the company's packaging box.
- Do not allow the equipment to be placed in humid, high temperature or outdoor exposure for a long time.

2.3 Precautions for handling



- At least two persons are required to move the device to a proper position, or use a forklift to move it.
- Keep the fluctuation height of the device as low as possible.
- Large shaking is prohibited, and the handling process of the equipment should be as smooth as possible.
- Handle gently to avoid shock or vibration. Be careful not to press your feet.
- When moving, pay attention to the ground level, and no sharp objects contact the ground.

3 Mechanical installation

3.1 Installation environment requirements

Table 5 Installation environment requirements

Items	Environment requirements
Site requirement	This product is installed in a cabinet and needs to be used in the final system
Pollution level	2
Altitude	4000m, if the altitude exceeds 3000m, the system should be derated.
Temperature	$-40^{\circ}\text{C}\sim+60^{\circ}\text{C}$, $+45^{\circ}\text{C}$ should be derated.
Humidity	0~95%RH

3.2 Installation space requirement

- If there is a baffle on the back of the STS module installation position, the baffle should be opened to avoid the port, so that the module can pass through the terminal (AC power terminal) through the baffle of the system cabinet, as shown in the following figure.
- Reserve space for power cable routing in the cabinet.

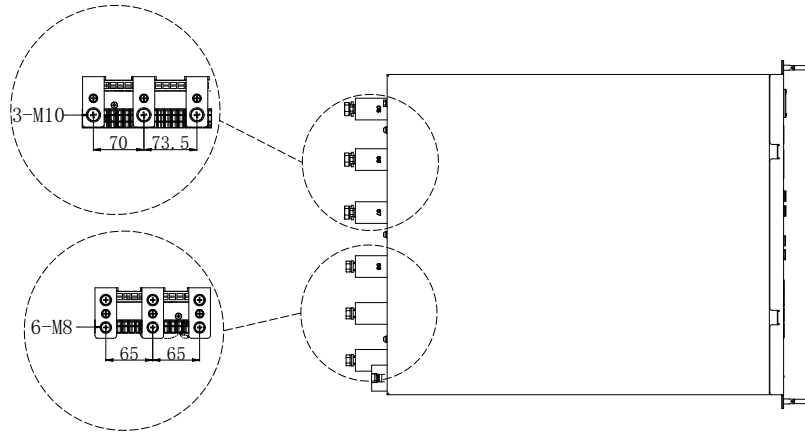

Figure 9 Through terminal diagram

3.3 Use of the module in the system cabinet

3.3.1 Cooling requirements

(1) Calculation of System Airflow: There are two methods for calculating system airflow:

Method 1: Calculation Based on Total System Loss

The system airflow can be calculated using the thermal formula:

$$V=Q/(Cp*\rho*\Delta T)$$

Where:

- C_p is the specific heat of air at the current temperature (kJ/(kg·K))
- ρ is the air density at the current temperature (kg/m³)
- The current temperature refers to the average temperature of the inlet and outlet air
- ΔT is the temperature difference between the inlet and outlet air (typically 18°C for outdoor cabinets)
- Q is the total system loss (in kW) (in regions with strong sunlight, the Q value should include solar radiation).

Using this formula, the system airflow V (m³/s) can be calculated.

Method 2: Calculation Based on Module Airflow

The airflow of a single YUNT STS module v is as follows:

The maximum airflow for the STS-120/200/250 module is 270 CFM (0.127 m³/s).

Thus, the total system airflow V can be calculated by:

$$V = n \cdot v$$

Where:

- n is the number of modules in the system,
- v is the airflow of a single module.

(2) System fan selection

System Fan Selection is determined by the system airflow V . The key parameters of the fan are the maximum airflow and static pressure. Under the condition that the fan's static pressure matches the system impedance, the maximum airflow of the system fan should be 1.5 to 2 times the system airflow, i.e., $(1.5 \sim 2) \times V$.

- If the fan has high static pressure and the system impedance is low, the maximum airflow can be closer to 1.5 times V .
- If the fan has lower static pressure and the system impedance is higher, the maximum airflow may need to be 2 times or even greater than 2 times V .

3.3.2 Cooling suggestions

The STS-120/200/250 modules used in the energy storage cabinet system should have a temperature difference ΔT between the inlet and outlet (including the cabinet inlet and outlet) not exceeding 20°C. The specific test points are shown in the diagram below:

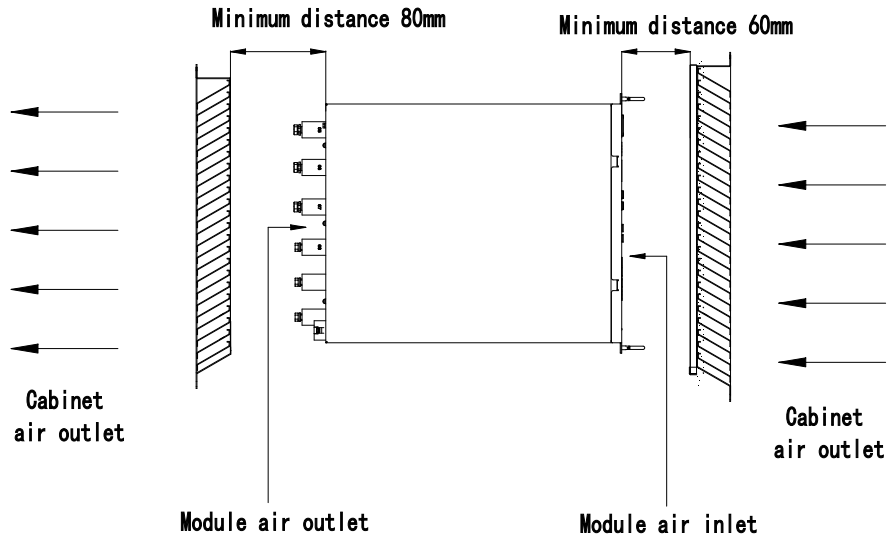

Figure 10 Diagram of the module in the system cabinet

3.4 Cable preparation

The power terminals of the STS module may be connected via copper busbars or cables. When cables are used, follow the wiring instructions in the table below.

Table 6 Recommended cable specifications

Connection position	Maximum voltage/current			Terminal specification	Cable recommendation (minimum)		
	STS-120	STS-200	STS-250		STS-120	STS-200	STS-250
GA/GB/GC	400V/182A	400V/304A	400V/380A	OT M10	Recommended current density: 3 A/mm ²		
LA/PA LB/PB LC/PC	400V/182A	400V/304A	400V/380A	OT M8	Recommended current density: 3 A/mm ²		
N				RV3.5-5S	3.5mm ²		
PE				OT M5	16mm ²		
+24V IN	24V/0.625A			GTJ0508	0.5~1mm ²		
+12V OUT	12V/0.15A			GTJ0508	0.5~1mm ²		
20PIN signal terminal	12V/0.5A			Socket Spring Clip Crimp Terminal	0.5~1mm ²		

PCS/STS/ ETH/CONS		Ethernet connector	Super Six lines
----------------------	--	-----------------------	-----------------

3.5 Installation

The installation procedure is as follows:

- (1) Hold the handle of the equipment with both hands, support the equipment with both hands, insert it into the corresponding position of the cabinet or directly use the lift truck;
- (2) Slowly push the device into the slot completely;
- (3) Fasten the four fixing screws on the device panel to the cabinet, and the installation torque is 6 N·m;
- (4) Install devices into the cabinet from left to right or top to bottom.

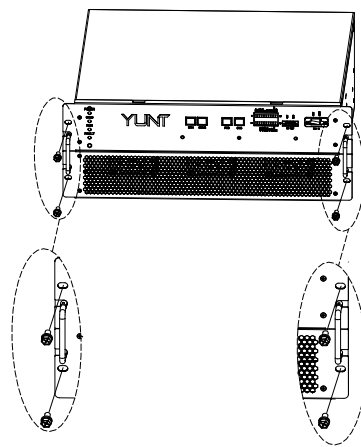

Figure 11 Installation diagram

4 Electrical installation

4.1 Pre-wiring inspection

To ensure the safety of personnel, necessary safety precautions must be taken when performing electrical installation of this product. The following procedures must be followed during the electrical installation:

- All power sources connected to the equipment must be turned off to ensure the equipment is in a disconnected state.
- Warning signs must be placed at the disconnection points to prevent the equipment from being re-energized during installation.
- Only qualified professionals should perform the installation. The installation process must strictly follow the instructions provided in the user manual.
- Installation personnel must comply with the relevant electrical operation regulations of the country or region where the installation takes place.
- Proper grounding connections must be made as required.

4.2 Precautions of wiring



- Before installation, disconnect all switches on the device and ensure that all external cables and internal devices are in the power supply state.
- Installation under live conditions is strictly prohibited.

4.3 Power terminal connection

The power terminals of STS module are at the rear of the module, including power grid side terminals, PCS side terminals, load side terminals, neutral (N) sampling terminal and ground terminals, as shown in the figure below. The functions of each terminal are defined in the following table.

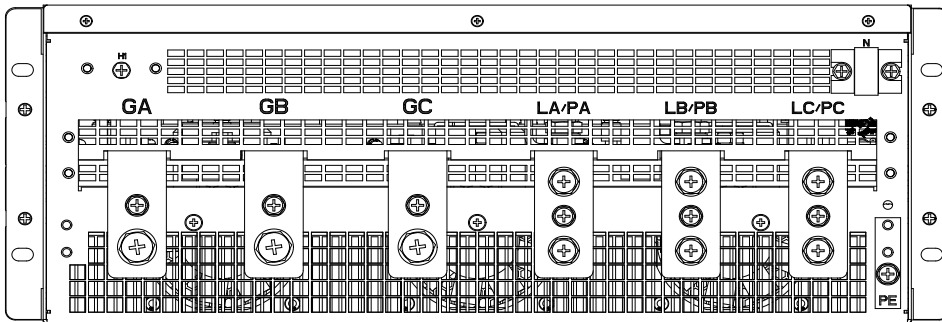

Figure 12 Diagram of power terminals

Table 7 Definition of power terminals

Position	Name	Description
Grid side	GA	Phase A(grid, OT M10 30N.M)
	GB	Phase B(grid, OT M10 30N.M)
	GC	Phase C(grid, OT M10 30N.M)
PCS and Load side	PA/LA	Phase A(PCS and Load, OT M8 14N.M)
	PB/LB	Phase B(PCS and Load, OT M8 14N.M)
	PC/LC	Phase C(PCS and Load, OT M8 14N.M)
Sampling	N	Grid neutral (PVC insulated ring terminal, M5)
Ground	PE	Grounding (Reliable grounding is required, OT M6 6N.M)

4.4 Signal terminal connection

The signal terminals of the STS module are located at the front of the module, including communication terminals, DIO terminals, and power terminals, as shown in the diagram below. The function definitions of each terminal are provided in the table below.

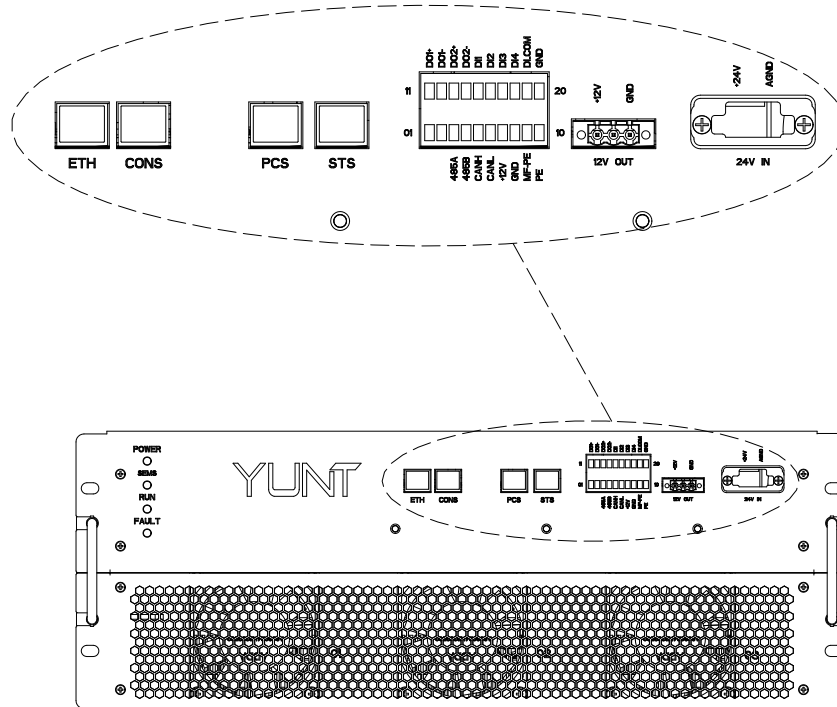

Figure 13 Diagram of signal terminal

Table 8 Definition of DC power terminal

Name	Interface	Function	Remark
24V IN	+24V	External +24V DC input (must be connected)	The power requirement for the power supply is 24V±15%/15W
	AGND		
12V OUT	+12V	Internal +12V DC output (2W)	
	GND		

Table 9 Definition of network port terminal

Terminal	Function	Description
PCS	Internal communication interface between STS and PCS	Used for communication with the PCS
STS	Internal communication interface	Used for parallel operation

	between STS modules	of STS modules
ETH	Reserved Ethernet communication	
CONS	Debug terminal	Connect debugging software (Intelligent Assistant)

Table 10 20PIN signal terminal definition

XDIO			
PIN	Signal name	Application	Remark
1			
2			
3	485A	Reserved 485 communication port	
4	485B		
5	CANH	CAN communication ports are reserved	
6	CANL		
7	+12V	+12V Output power supply	Power 6W
8	GND		
9	MF-PE	Ground	If the PCS and STS communicate via the fiber optic module, remove the jumper between pins 1 and 2, and use it to short pins 9 and 10.
10	PE		
11	DO1+	Reserved DO relay output	Relay dry contact output, supports 12 V / 0.3 A
12	DO1-		
13	DO2+		
14	DO2-		
15	DI1	Reserved DI input	12V&0.3A
16	DI2		
17	DI3		
18	DI4		
19	DI_COM	DI Common Ground	
20	GND	+12V output power ground	

The DI signal connection supports both external and internal power supply options. The connection methods are shown below.

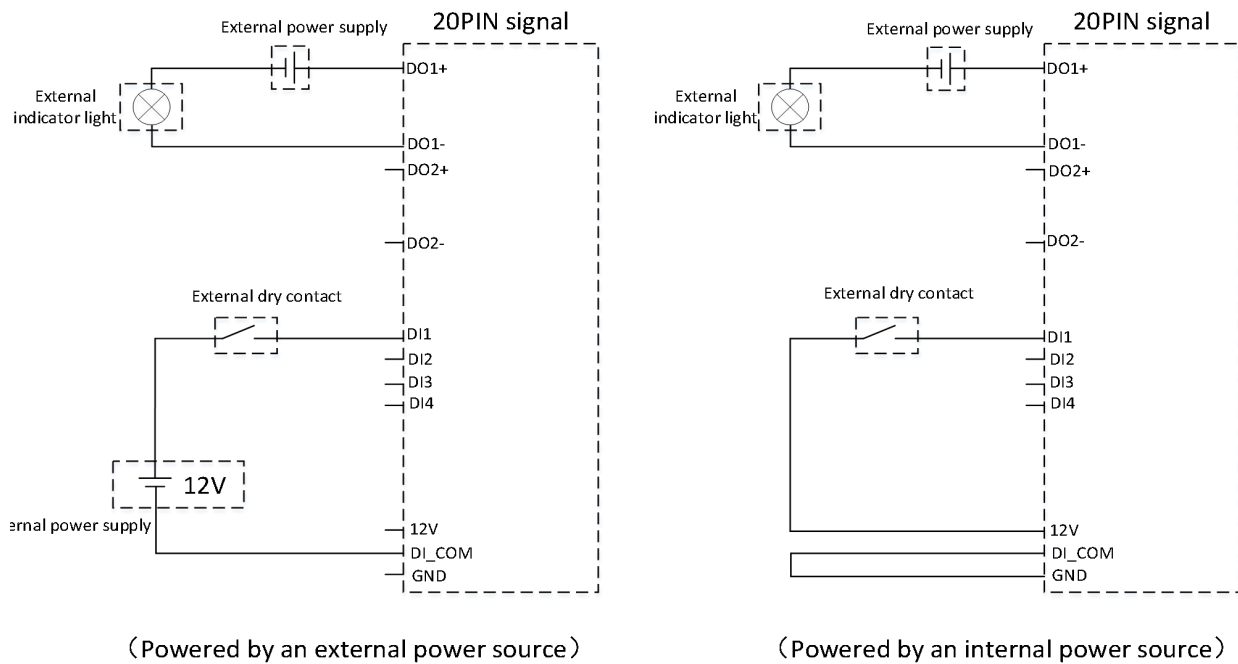

Figure 14 DI/DO Wiring Diagram

5 Initial Power-Up and Operational Startup

5.1 Power-On Operation Guide

Before powering on, check if the external three-phase power supply is normal. Once confirmed, follow the steps below:

- Disconnect the three-phase power supply to the STS module.
- Check that the three-phase power wiring, signal wiring, and communication wiring of the STS module are correct.
- Connect the three-phase power supply to the STS module and the external 24V power supply.
- Ensure the STS module is fault-free, then issue the "Power On" command to the PCS through the EMS.

Note:

- The STS module must be powered on strictly following the above steps; otherwise, it may damage the STS module or cause it to malfunction.
- After powering on, the STS module defaults to the off state, with the internal thyristor in the open position.

5.2 Power-Off Operation Guide

The normal shutdown procedure for the STS module is as follows:

- Issue the "Shutdown" command to the PCS through the EMS.
- The STS module automatically disconnects the internal thyristor.
- The fan continues to run for 5 minutes to cool down the STS module.
- Disconnect the external power switch of the STS module.

Note

- Place a warning sign at the switch to prevent accidental powering on by others.

6 Maintenance and Servicing

6.1 Routine maintenance

Each on-site maintenance should include a functional check of the STS module, mainly including:

- Check the connection cables.
- Check the operating status of the STS module.
- Check the switching of the STS module's operating mode.
- Check the indicator light status of the STS module.

6.2 Fault list

The STS-120/200/250 static transfer switch is equipped with comprehensive fault protection features. In the event of a fault, it will automatically shut down, and users can read the relevant fault information through the EMS.

Users can perform an initial self-check for faults based on the prompts in the following table, observe the fault symptoms, analyze the causes, and attempt to resolve the issue. Note: When performing a self-check for faults, do not remove the cover of the STS module. If the issue cannot be resolved, please contact your sales channel or YUNT.

The fault reset method is manual reset:

Manual reset for faults: After a fault occurs, once the fault conditions are identified and cleared, the user must manually reset the PCS through the EMS to return the STS module to normal operation.

Table 11 fault list

No	Fault name	Reset mode	Possible reasons	Handing methods
1	Grid over voltage	Manual	The AC input voltage is too high	Check if the grid voltage is normal.
2	Grid under voltage	Manual	The input voltage on the	Check if the grid voltage is

			AC side is too low	normal.
3	Grid over frequency	Manual	The input voltage frequency of the AC side is too high	Check if the grid frequency is normal.
4	Grid under frequency	Manual	The input voltage frequency of the AC side is too low	Check if the grid frequency is normal.
5	Incorrect Grid Phase Sequence	Manual	AC Side Input Voltage Phase Sequence Reversal	Adjust the AC side input voltage phase sequence.
6	Grid Phase Loss	Manual	AC side single-phase input voltage too low	Check if the grid voltage is normal.
7	+12V/-12V Power Supply Fault	Manual	The 12V auxiliary power supply is abnormal	Please contact the manufacturer.
8	STS module over temperature	Manual	Heat sink temperature too high	Check if the cooling fan is damaged.
9	Fan fault	Manual	Cooling Fan Damage	Please contact the manufacturer.
10	STS communication fault	Manual	Loose Communication Cable	Check the communication cables between the STS and PCS.
11	Grid Connection Switch Action Failure	Manual	Grid Connection Switch Driver Abnormality	Please contact the manufacturer.
12	PCS fault	Manual	STS reports PCS fault	Check PCS fault
13	Overcurrent in the power grid	Manual	Grid current exceeds the set protection value	Check the magnitude of the grid current
14	Load Overvoltage	Manual	Load voltage exceeds the set protection value	Check the magnitude of the grid current
15	Load Undervoltage	Manual	Load voltage is below the set protection value	Check the magnitude of the grid current
16	Load Phase Sequence Error	Manual	Load output voltage phase sequence is reversed	Check the phase sequence of AC input voltage and PCS output

6.3 Quality Assurance

Precautions:

- Products should avoid dust and moisture penetration to prevent damage or impact on product functionality.
- Maintenance should be performed when the power is fully turned off, discharged, and with no electrical current.
- After installation, protective measures should be taken to prevent direct contact with live parts.
- Products should be used strictly within the proper operating parameters specified in the user manual to avoid abnormal equipment performance.
- After operation, periodically check the product's ventilation conditions and clean dust from the operating environment.
- Avoid operating the product in environments with corrosive gases or pollutants.

Liability exemption:

The quality guarantee does not apply in the following cases:

- Damage caused by impact or improper operation during transportation, handling, or installation.
- Incorrect installation or modification.
- Exceeding the usage conditions specified in the product manual, such as overvoltage, overcurrent, incorrect input sources, abnormal external load devices, high or low temperature, and corrosive environments.
- Abnormal equipment caused by disassembly, repair, modification, or research by non-company personnel.
- Damage caused by changing the product's default protection parameters or operating and configuring the product using non-company software.
- Damage caused by abnormal natural environments.



Shenzhen Yunt Digital Power.,Ltd

Phone number: 0755-23592426

E-mail: sales@yunt-power.com

Website: www.yunt-power.com

Address: Building 1, No 15 Tianbao Road, Baoan District, Shenzhen City, Guangdong Province, China.